

**UNITED STATES DISTRICT COURT  
EASTERN DISTRICT OF NEW YORK**

SHANE LAVIN, Individually and on  
Behalf of All Others Similarly Situated,

Plaintiff,

v.

VIRGIN GALACTIC HOLDINGS, INC.,  
MICHAEL A. COLGLAZIER, GEORGE  
WHITESIDES, DOUG AHRENS, and JON  
CAMPAGNA,

Defendants.

Case No. 1:21-cv-03070-ARR-TAM

**PLAINTIFFS' FOURTH AMENDED COMPLAINT**

**TABLE OF CONTENTS**

I. INTRODUCTION ..... 1

II. JURISDICTION AND VENUE ..... 6

III. PARTIES AND IMPORTANT NON-PARTIES ..... 7

    A. Parties..... 7

    B. Important Non-Parties..... 8

IV. VIRGIN GALACTIC GOES PUBLIC THROUGH A REVERSE MERGER THAT NETS BRANSON MORE THAN \$150 MILLION AND PREVENTS PALIHAPITIYA FROM HAVING TO RETURN INVESTOR CAPITAL..... 13

V. DEFENDANTS’ MISCONDUCT..... 16

    A. Defendants Made False Statements About the February 2019 Flight ..... 19

        a. Unity nearly disintegrates on the February 2019 flight ..... 19

        b. “I Don’t Know How We Didn’t Lose the Vehicle and Kill Three People” ..... 21

        c. Virgin Galactic “Brush[es] [the incident] Under the Rug” ..... 23

    B. Defendants Falsely Stated that Unity and Eve Were Nearly Flight-Ready ..... 24

        a. Unity was not complete because it needed replacements for destroyed parts..... 25

        b. Unity and Eve were not complete because Virgin Galactic was building and installing the digital control system necessary to address uncontrollable shaking at Mach 1.5-2..... 26

    C. Unity and Eve Were Prototypes That Would Never Be Capable of Regular Flights ..... 30

        a. Defendants’ admissions ..... 33

        b. Unity and Eve were fragile prototypes ..... 33

        c. Virgin Galactic did not have accurate engineering drawings ..... 37

        d. Because Unity and Eve are made of carbon composite, Virgin Galactic will never be able to generate accurate engineering drawings ..... 49

VI. LOSS CAUSATION..... 50

a.	August 4, 2020 .....	50
b.	December 14, 2020 .....	51
c.	February 1, 2021 .....	53
d.	February 25, 2021 .....	55
e.	September 2-3, 2021 .....	56
f.	October 14, 2021 .....	62
g.	January 13, 2022 .....	64
h.	August 4, 2022 .....	65
VII.	DEFENDANTS’ FALSE STATEMENTS .....	66
A.	Defendants’ July 9, 2019 Announcement Of The Reverse Merger .....	66
B.	The Registration Statement .....	68
C.	September 2019 Prospectuses and Presentations .....	70
D.	Branson’s October 28, 2019 Bloomberg Interview .....	77
E.	Defendants’ December 13, 2019 Press Release .....	77
F.	Defendants’ May 5, 2020 Earnings Call (Q1 2020) .....	79
G.	Defendants’ June 25, 2020 Press Release .....	80
H.	Defendants’ November 2020 Press Release .....	80
I.	Defendants’ February 25, 2021 Earnings Call (Q4 2020) .....	81
J.	Virgin Galactic’s 2020 Form 10-K, filed March 1, 2021 .....	82
K.	Defendants’ May 10, 2021 Earnings Call (Q1 2021) .....	82
L.	Branson’s July 11, 2021 Interview .....	84
M.	Defendants’ August 5, 2021 Earnings Call (Q2 2021) .....	85
N.	Defendants’ May 5, 2022 Earnings Call (Q1 2022) .....	86
VIII.	ADDITIONAL FACTS FURTHER PROBATIVE OF SCIENTER .....	87

A.	Branson Offloads Virgin Galactic .....	88
B.	Virgin Galactic Raised More than \$1.3 Billion from Investors During the Class Period .....	94
C.	Palihapitiya Needed the Virgin Galactic Reverse Merger to Close To Prevent It and His Four Other SPACs From Failing .....	95
D.	Virgin Galactic Is A Small Company and Whitesides Worked There For More than a Decade .....	98
IX.	ADDITIONAL FACTS PLEADING COLGLAZIER’S SCIENTER .....	100
X.	CLASS ACTION ALLEGATIONS .....	103
XI.	APPLICABILITY OF PRESUMPTION OF RELIANCE: FRAUD ON THE MARKET DOCTRINE .....	105
XII.	NO SAFE HARBOR .....	106
	COUNT I .....	107
	COUNT II .....	108
	COUNT III .....	109
	COUNT IV .....	110
	PRAYER FOR RELIEF .....	114
	JURY DEMAND .....	115

## I. INTRODUCTION

1. This is a securities class action brought on behalf of all persons or entities who purchased or otherwise acquired the publicly traded common stock of Virgin Galactic Holdings, Inc. (“Virgin Galactic” or the “Company”) or Social Capital Hedosophia Holdings Corp. (“Social Capital”) from July 10, 2019, through August 4, 2022, inclusive (“Class Period”) and who suffered damages (“Class”). Plaintiffs bring claims under Sections 10(b), 20(a), and 20A of the Securities Exchange Act of 1934 (“Exchange Act”).<sup>1</sup>

2. At the beginning of the Class Period, Defendants marketed the reverse merger that would take Virgin Galactic public (“Reverse Merger”) as the chance to buy shares in the world’s first commercial spaceline. Defendants claimed they had built and successfully tested a system that was ready to take passengers to space, pointing to Virgin Galactic’s supposedly successful spaceflight in February 2019, and creating the misleading impression that Virgin Galactic was on the cusp of commercial spaceflight. In reality, when Virgin Galactic went public, its prototype spaceship, “Unity,” was grounded because a critical part necessary for safe operation had been destroyed in the February 2019 flight, nearly killing everyone aboard. Virgin Galactic was in the early stages of developing a space program with mere prototypes that Defendants knew would never be capable of regular commercial spaceflight. Aware of this material undisclosed information, Defendants Richard Branson and Chamath Palihapitiya sold more than one and a half billion dollars of Virgin Galactic shares to unwitting investors who relied on Defendants’ statements and were left with heavy losses.

---

<sup>1</sup> Excluded from the Class are: (i) Defendants; (ii) officers and directors of Virgin Galactic and Social Capital at all relevant times, and all subsidiaries thereof; (iii) persons or entities who held shares of Vieco 10 Ltd. as of July 9, 2019, and all subsidiaries thereof; (iv) the family members, heirs, assigns, and legal representatives of all persons set out in (i)-(iv); and (v) all entities controlled by the persons set out in (i)-(iv).

3. Virgin Galactic claimed to offer investors the chance to invest in the first company that would take private passengers to space. Defendants asserted they had successfully completed nearly all testing to complete the two vehicles in its space system: the carrier aircraft, Eve, that carried Unity to 45,000 feet; and the spaceship, Unity, that would supposedly carry passengers into space.

4. Defendants told investors that each of these ships had been designed, built, and assembled, with Eve ready for commercial service and Unity with just a few test flights left:<sup>2</sup>

**Fleet Build Progress and Expected Expansion Schedule**

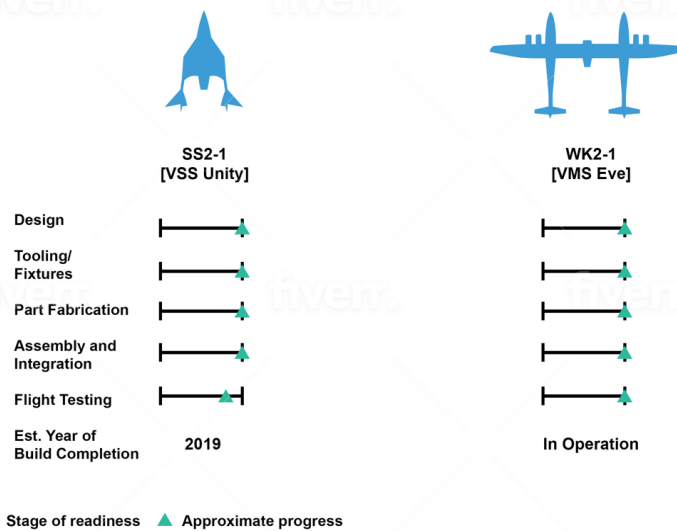

5. Defendants focused investors on two rocket-powered test flights, one in December 2018 and the other in February 2019, that they said had been successful and showed Virgin Galactic was on the cusp of commercialized spaceflight. For example, in a July 9, 2019, press release, Virgin Galactic claimed that “by demonstrating the repeatability of the full flight profile through the completion of two crewed spaceflights, ... [the Company] has overcome a substantial

<sup>2</sup> Source: September 5, 2019, presentation by Virgin Galactic (omitting two additional vehicles under construction).

number of the technical hurdles required to make the company a viable and profitable commercial service.” Branson similarly claimed in a July 9, 2019 letter filed with the Securities and Exchange Commission (“SEC”) that Virgin Galactic had “demonstrated the repeatability of our full flight profile with two crewed spaceflights.”

6. Defendants maintained that after completing tests and some minor modifications, Unity and Eve would be ready to go to space as frequently as other new spaceships that would roll off the factory floor, claiming Eve would fly “thousands” of spaceship launches and that Unity was “built for regular commercial service.”

7. In taking Virgin Galactic public, Defendants told investors the Company would begin regular commercial spaceflights around June 2020, fly 16 times in 2020, and start turning a profit by 2021 when it would launch 115 flights. As late as November 20, 2019, Defendant Palihapitiya still told investors that commercial flights “will begin in about six to nine months” and “[w]e’ll start commercial operations in the middle of next year.”

8. Defendants’ statements were misleading. Neither ship was anywhere near ready for regular commercial service and the February 2019 test flight that Defendants claimed “demonstrated the repeatability of the full flight profile” was no success; it was a near disaster. On the flight, a critical part necessary for survival, Unity’s horizontal stabilizers, had “popped,” which could easily have caused it to disintegrate midflight. Virgin Galactic grounded Unity following the February 2019 flight as it attempted to replace the destroyed horizontal stabilizers. Unity was still grounded when Virgin Galactic went public because it had not completed, let alone installed or tested, a replacement for the failed horizontal stabilizers. And Virgin Galactic still had to design, build, install, and test replacement for Unity and Eve parts that prior testing had shown were prone to break regularly or were unsuitable or unsafe.

9. Further, Unity and Eve would not be ready for commercial spaceflight by mid-2020, and, in fact, would only ever be able to make a token number of flights, far too few for commercial spaceflights. Rather, they were mere prototypes that had seen so many undocumented enhancements, and suffered so many stresses, that they could never fly anywhere near as frequently as required for actual commercial spaceflight. And Defendants did not have accurate engineering drawings of either Unity or Eve.

10. Thus, contrary to Defendants' statements, when Virgin Galactic announced that it would go public in a reverse merger, it had two old broken-down prototypes, one of which was grounded, a mile-long to-do list, and no clear path to commercialization, let alone commercial spaceflight by June 2020.

11. Defendants knew the facts that rendered their statements false. Virgin Galactic executives immediately raised the disastrous February 2019 flight with Virgin Galactic's Board and private shareholders, including Branson. Defendants learned in December 2019 *at the latest* that Virgin Galactic's engineering drawings were missing or inaccurate, when they were told that the installation of wiring was taking longer than expected, which occurred because engineers repeatedly had to revise plans that were formulated using the inaccurate drawings. In addition, in February 2021, after nearly two years of delays, Defendants were forced to admit that Unity and Eve had never been intended to be anything more than prototype test vehicles.

12. On February 25, 2020, during Virgin Galactic's Q419 earnings call, Defendant George Whitesides, Virgin Galactic's CEO from May 2010 through July 20, 2020, highlighted "our top priority of the year, which is to fly Richard Branson into space on a commercial flight in 2020." Whitesides trumpeted the Branson flight as "a powerful signal to the world that the next phase of commercial human space flight is beginning, and it will be a transformative moment for

the company and its employees, customers and stakeholders.” The flight was scheduled to occur in 2020. On July 15, 2020, CEO Whitesides assured investors that Virgin Galactic was “within spitting distance” of commercialization, claiming that “we are in a multi-month march to commercial ops.”

13. Then, on August 4, 2020, the Company delayed Branson’s flight to Q1 2021.

14. On December 12, 2020, Virgin Galactic attempted to fly Unity to space. When the Reverse Merger was announced in July 2019, Unity was not complete, contrary to Defendants’ statements at the time. For example, it had no flight controls, as it was in the middle of switching from a manual to a digital control system. As is common, the digital control system causes electromagnetic interference (“EMI”). On the December 12 flight, because of EMI, Unity lost a connection to its rocket motor, causing the flight to abort—which would never have happened if Unity had been complete in September 2019.

15. Then, on February 1, 2021, *The Washington Post* revealed that the February 2019 flight had nearly ended in disaster and gave further evidence of the extent of Virgin Galactic’s undisclosed problems. In the wake of the explosive *Washington Post* article, on February 25, 2021, Defendants finally admitted that Unity and Eve were mere prototypes that could never achieve rapid flight rates and sustain commercial flight.

16. Then, on September 2, 2021, the FAA grounded Virgin Galactic because on the test flight carrying Branson, which he had called “perfect,” Unity dangerously strayed from its FAA airspace.

17. With Eve and Unity mere rickety prototypes whose structure Defendants did not know, delays were inevitable. On October 13, 2021, Defendants announced they were taking Eve out of commission because tests had shown one of its parts may have been dangerously weak. And

on August 4, 2022, Defendants announced that they were further delaying commercial operations because they had had to revise plans to enhance Eve because Virgin Galactic's engineering drawings were inaccurate.

18. As a result of the foregoing disclosures, Virgin Galactic's stock price declined from a Class Period peak of \$62.80 to close at just \$6.76 on August 5, 2022, wiping out more than \$13 billion in shareholder equity.

19. Defendants, for their part and by their design, fared considerably better. Virgin Galactic raised almost a billion and a half dollars. Palihapitiya sold more than \$300 million of his own Virgin Galactic shares during the Class Period. Branson sold more than \$1.3 billion during the Class Period, more than 71.86 million shares, including selling over 10 million shares of stock for total proceeds of \$300 million in August 2021, just weeks before it was publicly revealed that during Branson's own July 2021 flight, Unity, had strayed from its landing cone and risked a crash landing.

20. In the end, in the three-and-a-half years since its 2019 SPAC public offering when it claimed to be on the cusp of commercialized spaceflight, Virgin Galactic has spectacularly failed to fly *any* paying passengers to space.

## **II. JURISDICTION AND VENUE**

21. The claims asserted herein arise under, and pursuant to, Sections 10(b), 20(a) and 20A of the Exchange Act, 15 U.S.C. §§78j(b), 78t(a), and 78t-1, and SEC Rule 10b-5 promulgated thereunder, 17 C.F.R. §240.10b-5.

22. This Court has jurisdiction over the subject matter of this action pursuant to 28 U.S.C. §1331 and §27 of the Exchange Act.

23. Venue is proper in this District pursuant to §27 of the Exchange Act and 28 U.S.C. §1391(b). Many of the acts charged herein, including the preparation and dissemination of materially false and misleading information, occurred, in substantial part, in this District.

24. In connection with the acts alleged in this Complaint, Defendants, directly or indirectly, used the means and instrumentalities of interstate commerce, including, but not limited to, the mails, interstate telephone communications, and the facilities of an electronic securities exchange located in this District.

### **III. PARTIES AND IMPORTANT NON-PARTIES**

#### **A. Parties**

25. Lead Plaintiffs Mark Kusnier and Robert Scheele, and Named Plaintiffs Xinqiang Cui, Justin Carlough, Jennifer Ortiz, Richard O’Keefe-Jones, Vipul Gupta, Maria Josephine Rosales, and Hesham Ibrahim purchased Virgin Galactic securities during the Class Period and were damaged thereby. Their certifications made pursuant to the Private Securities Litigation Reform Act of 1995 (“PSLRA”) were previously filed and are incorporated by reference.

26. Named Plaintiff Montgomery Brantley purchased or otherwise acquired Virgin Galactic common stock during the Class Period and was damaged thereby. His PSLRA certification is incorporated herein by reference.

27. Founded in 2004, Defendant Virgin Galactic is an aerospace company developing a system to take customers to space. Virgin Galactic’s shares trade on the NYSE under ticker SPCE. Virgin Galactic holds a subsidiary which builds vehicles (The Spaceship Company) and another that flies them (also called Virgin Galactic). In December 2020, The Spaceship Company and Virgin Galactic merged.

28. Defendant Richard Branson was throughout the Class period the controlling shareholder of Virgin Galactic. Branson has founded a series of companies in his career, most of which ended poorly. Branson is notorious for his outsized promises and attention-grabbing antics. During the Class Period, Branson's net worth was approximately \$5 billion. Excluding Virgin Galactic, a substantial majority of his investments were in illiquid private companies.

29. Defendant Chamath Palihapitiya served as the Chairman of the Board of Social Capital from its IPO through his abrupt departure in February 2022. He continued to serve as Chairman of the Board of Virgin Galactic after it merged with Social Capital. From 2007 to 2011, Palihapitiya worked at Facebook, becoming a senior executive. After leaving Facebook, he started The Social+Capital Partnership, a venture capital firm, which he later renamed Social Capital ("Social Capital Fund"). Palihapitiya began creating a series of SPACs, starting with Social Capital, listed under the ticker symbol IPOA. This entity eventually merged with Virgin Galactic. Palihapitiya reserved the ticker symbols IPOA through IPOZ.

30. Defendant George Whitesides was Virgin Galactic's CEO from May 2010 through July 20, 2020. When Whitesides joined Virgin Galactic, it had 30 employees.

31. Defendant Michael Colglazier has served as CEO and as a member of Virgin Galactic's Board of Directors since July 2020. He has also served as President since February 2021.

32. Defendants Branson, Palihapitiya, Whitesides, and Colglazier are the "Individual Defendants."

**B. Important Non-Parties**

33. Former Employee 1 ("FE 1") worked as Chief Inspector/Quality and Regulatory Compliance of Virgin Galactic's Technical Operations Group from June 2019 through December

2020. Until February 2020, FE 1 reported to Director of Regulatory Compliance Greg Fredenburg, who reported to Moses. Thereafter, FE 1 reported to Pedro Caballer, Virgin Galactic's Director of Technical Operations, who reported to Michael Moses, Virgin Galactic's President—Missions and Safety. FE 1 oversaw Virgin Galactic's Quality Assurance department, which included attempting to ensure that technicians documented the maintenance for Unity and Eve. FE 1 created and oversaw a team of three technicians who conducted visual inspections of the vehicles. FE 1 also created and oversaw a non-destructive testing team of six technicians, who tested vehicles to determine their capabilities, structures, and status, without destroying them. Finally, FE 1 oversaw Virgin Galactic's regulatory compliance department. FE 1 left Virgin Galactic because "I wasn't comfortable signing off" on paperwork asserting Unity was safe to fly in light of Virgin Galactic's dangerous practices.

34. Former Employee 2 ("FE 2") worked as an Associate Systems Safety Engineer at Virgin Galactic from August 2017 through January 2019. FE 2's main job duties related to performing FAA System Safety Analysis, including for Eve, but primarily for Unity. FE 2 conducted fault tree analyses after incidents or accidents. FE 2 reported to Issa Mukhar, who reported to Thom Howell and Pete Nickolenko, who both reported to Moses. FE 2 left Virgin Galactic in January 2019. Later that month, the remaining four members of the Safety and Engineering team were all laid off, including Mukhar.

35. Former Employee 3 ("FE 3") worked as a Virgin Galactic technician from August 2014 through October 2018. FE 3's formal title was "Space Wrench," which is what Virgin Galactic calls its technicians. FE 3 reported to Crew Chief Matt Coss until mid-2015 when Coss was replaced by Chad Rosacker. Rosacker and Coss reported to Rich Mondoux, Virgin Galactic's Director of Maintenance, who reported to Caballer, who reported to Moses.

36. Former Employee 4 (“FE 4”) worked as a Virgin Galactic Space Wrench from September 2017 through January 2018. He reported to Rosacker, a Crew Chief, who reported to Mondoux, who reported to Moses. FE 4 performed whatever general maintenance on Unity and Eve was necessary to prepare them for launch, including completing engineering orders, drilling holes, and putting rivets on the vehicles.

37. Former Employee 5 (“FE 5”) worked at The Spaceship Company from 2011 through October/November 2019. Until about November 2018, FE 5 worked as Quality Supervisor and Quality Engineer. FE 5 worked on the “entirety” of Unity. FE 5’s day-to-day responsibilities included receiving engineering orders from Engineering and breaking them down into individual tasks for technicians to perform. FE 5 also supervised the Quality Inspectors, who were supposed to oversee the technicians’ adherence to the engineering instructions. FE 5 reported to Director of Quality Assurance Cecil Whaley, who reported to Enrico Palermo, The Spaceship Company’s President, who reported to Whitesides. For the last year of FE 5’s employment, FE 5 served as The Spaceship Company’s Build Manager for Interiors, responsible for achieving schedules and deadlines.

38. Former Employee 6 (“FE 6”) served as The Spaceship Company’s Production Manager from July 2015 through July 2017 and its Deputy Program Manager—Build from July 2017 through March 2020. Before joining The Spaceship Company, FE 6 worked for 26 years at Scaled Composites, for the last 23 years as crew chief. While at The Spaceship Company, FE 6 had overall responsibility for building and maintaining Unity. While at Scaled Composites, FE 6 was the Crew Chief for Enterprise, Unity’s progenitor, and was responsible for its safety. FE 6 was also a crew chief involved in building SpaceShipOne, Scaled Composites’ first rocket-propelled vehicle. When FE 6 left, FE 6 reported to Tony Montoya, the Director of Manufacturing,

who reported to Tom Pugh, Senior Vice President—Programs & Engineering, at The Spaceship Company.

39. Former Employee 7 (“FE 7”) worked at Virgin Galactic from March 2015 through January 2019. Until the end of 2017, FE 7 was a Manufacturing Engineer responsible for assessing the feasibility of manufacturing parts intended for use in Virgin Galactic vehicles. FE 7 initially reported to Darren Laughrin. Then, after Laughrin’s promotion to Vice President of Operations, FE 7 reported to Brian Bell, who reported to Laughrin. After FE 7’s promotion, Laughrin reported to Palermo, the President of The Spaceship Company. From January 2018 on, FE 7 provided Engineering Support for Structural Systems, which entailed reviewing the designs of mechanical systems on the Virgin Galactic vehicles, primarily Unity, and assessing whether Virgin Galactic could source any of the hardware it had been using to reduce the amount of custom-made hardware. FE 7 reported to Joe Brennan and Tony Montoya, who operated in parallel and reported to Laughrin.

40. Former Employee 8 (“FE 8”) started work as a Virgin Galactic contractor in August 2019 but was quickly hired as an employee. FE 8 was the lead Materials & Processes Group Engineer, first at The Spaceship Company from August 2019 through January 2021, then at Virgin Galactic from January 2021 through August 2021. FE 8’s responsibilities included designing and overseeing an inspection process for Eve and Unity.

41. Former Employee 9 (“FE 9”) worked as a Virgin Galactic Structure Design Engineer out of its Mojave office. FE 9 started work in March 2019. FE 9 worked on Eve until September 2020, focusing on the connections between Eve’s inner wing and its fuselage (its “armpit”), when FE 9 was shifted to designing Unity’s interior. FE 9 remained with Virgin Galactic until January 2021.

42. Former Employee 10 (“FE 10”) worked as a Virgin Galactic contractor beginning in 2018 or 2019 and continued until FE 10 was hired as a full-time employee in June 2021. FE 10 remained with Virgin Galactic until September 2022 and was a Senior Technical Writer. FE 10’s responsibilities included creating maintenance manuals. To do this work, FE 10 relied on numerous Virgin Galactic repositories of technical procedures, as well as discussions with various Virgin Galactic engineers, technicians, and inspectors. When FE 10 left Virgin Galactic in September 2022, the Company had not completed a single maintenance manual. At the time, it aimed to complete a manual for “safety critical items” by November 2022, although the deadline had been extended several times in the past.

43. Nicholas Schmidle is a *New Yorker* Staff Writer who was embedded in Virgin Galactic from late 2014 through about July 2018. During this time, Schmidle was provided documents, had nearly unlimited access to Virgin Galactic, made 16 trips to Virgin Galactic’s Mojave Desert offices, and was free to attend nearly any meeting and talk to any employee. Schmidle formed close relationships with Virgin Galactic employees that continued after his visits. Schmidle maintained a close relationship with Mark Stucky, Virgin Galactic’s lead pilot, among others. Schmidle wrote a book based on his experience embedded in Virgin Galactic titled *Test Gods: Virgin Galactic and the Making of a Modern Astronaut*, published May 4, 2021. As Schmidle sets out in the author’s note, “when I finished writing *Test Gods*, I then provided an annotated manuscript, with citations for every factual assertion in the text, to a professional fact-checker who spent months re-reporting the book—re-interviewing sources, consulting documents, re-reading archival material—to ensure its accuracy.”

44. Mark Stucky was Virgin Galactic’s lead test pilot from February 2015 through July 2021. Before joining Virgin Galactic, he was a test pilot for Scaled Composites, flying Eve and

Unity's progenitor. Stucky had a storied career in the United States Air Force, was the first Virgin Galactic pilot to fly to space and is regarded as one of the best test pilots in the world. Virgin Galactic fired Stucky in a Zoom meeting in July 2021 after he raised concerns about Virgin Galactic's safety to Schmidle. Stucky is a principal source for, and the subject of, *Test Gods*.

45. Todd Ericson served as Virgin Galactic's Vice President—Safety and Testing, as well as one of its test pilots, from December 2014 through June 2019. Ericson resigned in protest because Virgin Galactic was not taking safety seriously.

46. Greg V. Meholic is a Senior Project Leader at The Aerospace Corporation. Meholic has 29 years of experience encompassing both aircraft and space system development. He has six years of experience with aircraft propulsion design, servicing and manufacturing, and 20 years of experience with space launch concept development and design, vehicle and ground support systems and hardware, integrated space systems engineering, test and qualification processes, anomaly detection and resolution, manufacturing, and missions operations. Meholic has provided real-time support to more than four dozen space launches and also has 27 years of college-level teaching experience in aircraft design, aerospace engineering, propulsion system design and product familiarization. Meholic has experience with many aspects of space vehicle construction, from the drawing board through the shop floor, flight qualification, and launch.

#### **IV. VIRGIN GALACTIC GOES PUBLIC THROUGH A REVERSE MERGER THAT NETS BRANSON MORE THAN \$150 MILLION AND PREVENTS PALIHAPITIYA FROM HAVING TO RETURN INVESTOR CAPITAL**

47. Social Capital's IPO took place on September 18, 2017. It sold 69 million \$10 units, each consisting of one share and one third of a warrant to purchase a share for \$11.50, for total proceeds of \$690 million.

48. Social Capital is a Special Purpose Acquisition Corp (“SPAC”). SPACs like Social Capital are publicly-traded holding companies founded to take a private company public through a reverse merger. As is typical for SPACs, if Social Capital consummated a transaction with a private company, its sponsors (including Defendant Palihapitiya) would receive large stakes in the new public company for no additional consideration. Otherwise, Social Capital would be wound down and its funds returned, leaving the sponsors with nothing to show for two years’ efforts.

49. Social Capital had until September 18, 2019, to consummate a transaction. It announced that it had reached an agreement to enter into the Reverse Merger with Virgin Galactic on July 9, 2019, with just two months to go.

50. The Reverse Merger’s terms included:

- a. Virgin Galactic’s existing shareholders would be issued 130 million shares at \$10 each, giving existing Virgin Galactic a valuation of \$1.3 billion;
- b. Social Capital’s existing shareholders, including its sponsor and affiliated entities to the extent of their respective existing Social Capital shareholdings, would hold about 65 million shares;
- c. Social Capital’s sponsors would be issued 15.75 million new shares for free;
- d. Boeing would purchase about 1.9 million shares;
- e. Defendant Palihapitiya would purchase 10 million shares for \$100 million directly from an investment vehicle 80.7% owned by Defendant Branson’s vehicle, Vieco 10 Ltd. (“V10”);
- f. Social Capital shareholders could tender their shares for about \$10 each up to the time of the Reverse Merger;

- g. Defendant Branson could force Virgin Galactic to repurchase V10’s shares provided the following two conditions were met: (a) Virgin Galactic purchased less than \$200 million of V10’s Virgin Galactic’s shares; and (b) Virgin Galactic still held \$500 million in its trust account after purchasing V10’s Virgin Galactic shares.
- h. V10 agreed to a lockup preventing it from selling more than 50% of its Virgin Galactic shares for two years after the Reverse Merger, or until October 2021.

51. In the Reverse Merger, which closed on October 25, 2019<sup>3</sup> (a) Branson did elect to force Defendant Palihapitiya to purchase 10 million of V10’s Virgin Galactic shares; (b) shareholders holding 15.8 million Social Capital shares tendered their shares for total consideration of about \$159.8 million; (c) V10 elected to force Virgin Galactic to repurchase 5,209,562 of V10’s Virgin Galactic shares, or the maximum amount allowed; and as a result, (d) \$500 million remained in the Social Capital trust account, before additional expenses. Thus, Branson withdrew every dollar he could from Virgin Galactic.

52. As a result, Virgin Galactic’s equity capital structure immediately after the Reverse Merger was:

V10	114.8 million shares
Social Capital’s public shareholders	53.1 million shares
Social Capital Sponsors and related parties	25.8 million shares
Boeing	1.9 million shares
Shares issued to settle transaction costs	0.4 million shares
<b>Total</b>	<b>196.0 million shares</b>

---

<sup>3</sup> Social Capital received an extension of the 2-year deadline from its shareholders to complete the Reverse Merger.

## V. DEFENDANTS' MISCONDUCT

53. Beginning with the announcement of the Reverse Merger, Defendants' pitch to investors was that Virgin Galactic was about to become the world's first commercial spaceline, Virgin Galactic's neologism for a company that flies passengers to space. Commercial operations were not mere speculation for the distant future. They would come, and soon: by June 2020. Investors would own a share in a company that was, for the first time, regularly taking passengers to a place the U.S. legally defines as space.

54. The pitch was a matter of dollars and cents. Developing, building, and maintaining space vehicles is exorbitantly expensive. At the time of the Reverse Merger, Virgin Galactic was burning through \$16 million per month. It earned trivial revenues, less than \$3 million in 2018. Until commercialization, it would keep burning through its capital. Protracted delays meant it would have to raise more funds, diluting investors.

55. So, Defendants told investors, commercial flights were just around the corner. Announcing the merger, Whitesides wrote that Virgin Galactic had reached an "advanced point." The Reverse Merger would suffice to "provide the additional capital required to meet our operational objectives as we transition from test to commercial operations and ultimately to a profitable enterprise."

56. Branson told investors that "Opening Virgin Galactic to further external investment has been on the cards for a while. Great progress in our test flight program means that the remaining hurdles, before our beautiful spaceship starts a full commercial service, are steadily being cleared." And in an October 28, 2019, Bloomberg TV interview, he added that "using the money that we've raised today [in the Reverse Merger], we can build a lot more spaceships and

motherships, and a lot more rockets, and we can build the numbers of people that are able to go into space.”

57. Thus, according to Branson, Virgin Galactic had completed the development portion of its life and it was about to start earning money.

58. To convince investors that there were currently no problems in Unity’s testing program, Defendants told investors that Unity had flown to space twice, and that its second flight in February 2019 had been an unqualified success. In fact, on that flight, Unity had nearly disintegrated midflight and suffered such catastrophic damage to its horizontal stabilizers that it was still grounded and would remain so until May 2020.

59. Defendants also represented that Unity and Eve were all but complete. As excerpted in ¶4 above, Defendants told investors that Eve was fully built, assembled, integrated, tested in flight, and ready for commercialization. While Unity still had a very small amount of flight tests remaining, it was also built, assembled, and integrated. At the very moment Defendants made these representations, Unity was grounded because it had no horizontal stabilizers or flight control systems. Beyond these specific parts, Unity and Eve would each have to be overhauled before any commercial operations, because they were rickety prototypes that could not withstand regular flights.

60. Defendants also laid out their plans to build new spaceships and carriers to increase Virgin Galactic’s future flight capacity. Defendants consistently discussed Unity and Eve as if they were equivalent to vehicles rolling off the factory floor. They also told investors that Unity was “built for regular commercial” spaceflight. But unbeknownst to investors, and well known to Defendants, Unity and Eve would never be able to reach a flight cadence comparable to new vehicles. They were prototypes that had been damaged by the stress of testing, and worse, the

Company did not have accurate engineering drawings. With no accurate engineering drawings, Virgin Galactic was forced to conduct lengthy inspections and repairs after every single Unity and Eve flight. As mere prototypes, it was impossible for Unity and Eve to perform more than a token number of flights.

61. Based on these misrepresentations, Defendants provided investors with a timeline showing commercial flights just around the corner. On the very day the Reverse Merger was announced, Defendant Palihapitiya represented in a public interview that “You know, we’re going to be starting commercial operations within a year from now, which is really exciting.” In November 2019, he reiterated that commercial flights were six to nine months away. These deadlines were not remotely achievable.

62. With commercial operations starting in July 2020, Defendants estimated that Unity would complete 16 commercial flights in 2020, generating \$31 million in revenues, and Virgin Galactic would complete 115 commercial flights in 2021, largely on Unity, generating \$210 million in revenues.

63. Defendants told investors detailed facts to spin a fantastical tale that Virgin Galactic was on the cusp of regularly flying paying passengers to space. Yet these facts were false, and Defendants’ tale collapsed with them. At the time of the Reverse Merger, Virgin Galactic had two beaten-up, badly designed prototypes whose actual structure was a mystery to Defendants. The prototypes would never be profitable and could not even conceivably earn revenues until years in the future. Investors lost billions.

**A. Defendants Made False Statements About the February 2019 Flight**

*a. Unity nearly disintegrates on the February 2019 flight*

64. Virgin Galactic's system has two parts: a carrier aircraft, or mothership, and a spaceship. The mothership takes the spaceship to about 45,000 feet, and then releases it. The spaceship then activates its rocket engine. Flying under its own power nearly vertically, the spaceship reaches approximately 275,000 feet, which is, under U.S. law, technically in space. The spaceship stays in space for a few minutes, and then starts gliding back down to Earth.

65. Burt Rutan's Scaled Composites developed the design that Virgin Galactic adopted. Scaled Composites is known for developing proof-of-concept prototypes, not commercial vehicles. Its methods reflect its focus: both its testing and documentation are shoddy.

66. Nevertheless, VG retained Scaled Composites to build Eve and Unity's precursor, Enterprise.

67. In October 2014, Enterprise disintegrated midflight during a test flight, killing the copilot.

68. Virgin Galactic recognized that the October 2014 accident was an existential threat. Accordingly, it purportedly overhauled its testing program.

69. Virgin Galactic started by severing its relationship with Scaled Composites. From then on, Virgin Galactic's vehicles would be built by its sister company, The Spaceship Company.

70. Enterprise's disintegration had temporarily left Virgin Galactic without a spaceship. Yet the delay would not be very long. In 2012, before Virgin Galactic severed the relationship, Scaled Composites had begun building another SpaceShipTwo model, later dubbed VSS Unity. As of early November 2014, Unity was about 65% complete. The Spaceship Company then took over.

71. Unity was unveiled in February 2016. It then began flight testing.

72. Unity's testing regimen called for three types of flight tests. In the first and least risky type of test, a captive carry flight, the mothership takes the spaceship to 45,000 feet but does not release it. In the second, glide tests, the mothership releases the spaceship, but it does not engage its rocket motor. Instead, after release, the pilot glides the spaceship down to a landing strip. Glide tests are more risky than captive carry tests. In the third, the riskiest tests, after being released, the spaceship engages its rocket motor for up to the full 60-second planned blast necessary to enter space. Undiscovered flaws or pilot error can destroy the shuttle on such powered flights.

73. On January 11, 2018, Virgin Galactic launched one last glide flight before beginning powered flights. The pilot, Stucky, was to reach Mach 1 and test maneuvers during a dive to determine whether Unity would respond adequately in various circumstances. One of these tests called for Stucky to slam Unity's center stick to see how it responded, thus highlighting any issues related to its pitch. When he did, Unity wobbled. The wobbling continued, so Stucky tried to pull out of the dive, but a flashing red light in the cockpit indicated that the left horizontal stabilizer was stuck. If the error continued, Unity would flip upside down.

74. Unity's first powered flight took place on April 5, 2018. The flight plan called for the pilot, Stucky, to run Unity's rocket for 30 seconds. But when Unity reached Mach 1.8 at 60,000 feet, it began shaking violently. Stucky called out "abort, abort, abort!" As it was already going nearly Mach 2, Unity continued to climb, reaching nearly 85,000 feet. But then Unity's gyroscopes failed. Stucky noticed that they showed Unity as right side up when, in truth, it was upside down. Stucky remarked that his instruments were all "messed up." The error nearly took Unity off course. If it had, the flight would have ended in a crash landing.

75. On July 26, 2018, Unity flew again under its own power. According to Schmidle, during the flight, Unity started tumbling, and the pilot David Mackay exhausted Unity's main Reaction Control Systems (air jets that are used to orient Unity in space) ("RCS"), and nearly exhausted its backup RCS, trying to right the ship. Yet Unity was still spinning out of control. Its recommended pitch rate, the rate of change of aircraft orientation relative to an inertial frame, was only five degrees per second, but Unity's pitch rate then was fifty degrees per second, so the shuttle would complete a revolution in only slightly more than seven seconds. According to FE 2, the pilot's overuse of RCS was inadvertent. Unity's yoke, the device the pilot uses to steer Unity, can be moved 360 degrees. When the pilot pulls it to the far side, he or she can accidentally trigger the RCS system.

76. In December 2018, Unity reached space for the first time. On that flight, Unity began veering off course after 30 seconds of burn. Because Unity glides to its landing with no rocket power, "veering off course" can easily mean a crash landing. Then, Stucky rolled left to try to level the wings, but instead rolled all the way over, at Mach 2, and kept rolling. As Schmidle wrote, "[t]hey were in unknown, uncharted aerodynamic territory[.]".

77. Unity's next landmark was taking a "passenger" to space. That flight was scheduled for February 22, 2019.

b. *"I Don't Know How We Didn't Lose the Vehicle and Kill Three People"*

78. According to two separate journalists whose reports largely confirm each other, Unity suffered critical damage to its horizontal stabilizers during the February 2019 flight. The damage was so significant that Virgin Galactic's head of safety Todd Ericson told Schmidle "***I don't know how we didn't lose the vehicle and kill three people.***"

79. In a February 2, 2021, post, blogger Doug Messier, who publishes the [www.parabolicarc.com](http://www.parabolicarc.com) blog focused on space (“Messier Post”), quoted a Virgin Galactic insider as stating that Unity’s whole horizontal stabilizers ruptured. According to Messier, the cover-up began during the flight. Messier quotes an insider as stating that the pilots “[l]anded long to avoid media cameras”<sup>4</sup> who were there to film the shuttle’s arrival.

80. According to Schmidle, when the crew wheeled the shuttle into the hangar, both Stucky and Ericson immediately noticed a large gash running along the trailing edge of the right horizontal stabilizer. In Schmidle’s words, when Moses arrived and saw the gap, he “felt his stomach sink.”

81. Stucky told Schmidle “[i]t looked like someone ripped the caulking out of a bathtub.” Ericson told Schmidle “[t]he structural integrity of the entire stabilizer was compromised.”

82. Messier’s source corroborates Schmidle’s account. He quotes the source as saying that Unity’s elevons (a portion of horizontal stabilizers) were “[w]ay too damaged to fly again. Whole structure ruptured.” Messier quotes the insider as stating that the February 2019 flight was “a close call”.

83. According to FE 6, Virgin Galactic was “super lucky.” The horizontal stabilizer “popped like a bag of chips”, but in the “right spot.” Had the horizontal stabilizer popped elsewhere, the crew would have been killed.

---

<sup>4</sup> Landing long refers to landing either too fast or past the landing spot, such that the shuttle comes to rest further than anticipated. Landing long is dangerous. When the conditions for a long landing appear, commercial airplane pilots often abort the landing entirely, coming up for a second landing.

c. *Virgin Galactic “Brush[es] [the incident] Under the Rug”*

84. Virgin Galactic immediately grounded Unity after the nearly disastrous February 2019 flight. As Ericson told Schmidle: “This should have been a come-to-Jesus moment, ***not the kind of thing you brush under the rug.***”

85. But Schmidle reports that the company tried to keep the problem quiet, worried that it might spook investors in advance of going public. In the following days, Defendants told the press the flight was an unqualified success. Indeed, Defendant Branson stated in a press release:

Having Beth [Moses] fly in the cabin today, starting to ensure that our customer journey ***is as flawless as the spaceship itself***, brings a huge sense of anticipation and excitement to all of us here who are looking forward to experiencing space for ourselves. The next few months promise to be the most thrilling yet.

86. Defendant Whitesides told the Associated Press the flight was so successful Virgin Galactic was shifting its priority to developing its cabin:

That’s not to say that we are fully done with vehicle testing, but we really are starting to move into the interiors testing phase, and that’s a really important milestone for the company.

87. Virgin Galactic never voluntarily disclosed the problems with the February 2019 flight.

88. On June 10, 2019, upset that Moses was not taking his concerns seriously, Ericson told Whitesides that he was resigning. Schmidle wrote that “Whitesides looked stricken; his vice president of safety was resigning because he’d lost confidence in the safety regime.”

89. Defendant Moses later told the Washington Post that after the February 2019 flight, “the company ***immediately notified board members and shareholders*** as well as the FAA and ***‘kept them apprised regularly of what we were finding, as well as the corrective actions.’***” At the time, Branson was Virgin Galactic’s largest shareholder.

90. Thus, Defendants' statements touting the February 2019 flight as a success were false.

**B. Defendants Falsely Stated that Unity and Eve Were Nearly Flight-Ready**

91. In addition to misrepresenting Unity and Eve's testing history, Defendants overstated Virgin Galactic's proximity to commercial operations.

92. As excerpted in ¶4, Defendants represented that for both Unity and Eve, Virgin Galactic had completed design, tooling/fixtures, parts fabrication, assembly, and integration. Eve had completed its test flights and there were only a few test flights remaining for Unity.

93. And because Unity and Eve were nearly complete, Defendants told investors, commercial flights were impending. In July 2019, Defendants said commercial flights would come within a year. In September 2019, Defendants said commercial spaceflights would commence by June 2020. On November 20, 2019, in an interview with CNBC, when asked, "[s]ince its listing, [Virgin Galactic is] down 20%, do you think the performance would have been different if it had gone the route of an IPO versus a direct listing?" Palihapitiya responded, "Not really .... The story of Virgin is just so new it just hasn't even been written yet. The reality is we will start commercial operations in the middle of next year. And so the full-fledged business value will become apparent very quickly to a lot more people at that point. And so everything that happens between now and then quite honestly is a lot of people hedging, some people speculating but it's really, the there there will begin in six to nine months."

94. Defendants' statements were false. Unity's design, fabrication, and assembly were not complete because, among other things, it still did not have horizontal stabilizers, having destroyed its last set on the February 2019 flight. Nor did it have a working set of controls, because it was in the middle of replacing its old manual controls. With the old controls, Unity shook

uncontrollably at speeds of Mach 1.5-2.0. The new digital controls aimed to automatically control the shaking, but they had not been tested and risked introducing problems of their own.

*a. Unity was not complete because it needed replacements for destroyed parts*

95. According to Schmidle, the February 2019 flight irreparably damaged Unity's horizontal stabilizers.

96. According to FE 1, Virgin Galactic hired the National Institute for Aviation Research at Wichita State University to build new aluminum horizontal stabilizers.

97. Schmidle likewise reports that Virgin Galactic hired a firm from Wichita to build new metal horizontal stabilizers.

98. According to FE 8, building horizontal stabilizers out of aluminum rather than composite materials added 120 pounds to Unity, or almost 1% of its existing weight.<sup>5</sup> The added weight necessitated more substantial modifications to Unity.

99. The Messier Post quoted a Virgin Galactic insider as saying that the destruction of the horizontal stabilizers "explains lengthy grounding and then the glide[] [flights] in [New Mexico]", which took place in May 2020.

100. Nor was Eve built for commercial flights. In preparation for a December 6, 2019, meeting ("December 2019 Board Meeting"), Virgin Galactic's Board (including Defendants Palihapitiya and Whitesides, as well as Defendant Branson's three board designees) received a November 29, 2019 memo ("November 2019 Memo") explaining that:

Particular focus is on [Eve's] pylon structure which attaches the spaceship to the jet...Right now, the team is leaning towards putting on a new pylon. This modification would not need to take place before [Branson's] flight, but it may be good to do before the start of ongoing commercial operations.

---

<sup>5</sup> Virgin Galactic tweeted on December 3, 2020, that Unity weighed 15,800 pounds. <https://twitter.com/virgingalactic/status/1334610284984623119>

101. A presentation at the December 2019 Board Meeting focused exclusively on “VMS Eve Launch Pylon” and explained that it “has certain design limitations and has been the subject of on-going structural analysis for long-term commercial service.”

102. Thus, neither Eve nor Unity were complete because they each needed replacement parts without which they could not undertake commercial flights.

*b. Unity and Eve were not complete because Virgin Galactic was building and installing the digital control system necessary to address uncontrollable shaking at Mach 1.5-2*

103. Virgin Galactic also spent time remedying a few of the defects it had known about for years. One of these problems is that Unity shook uncontrollably at certain speeds, precluding commercial flights.

104. Winged vehicles create shockwaves as they fly through the air at speeds above Mach 1. The shockwaves hit different portions of the vehicle at different angles depending on the air’s local speed over the airframe. For example, when a vehicle is travelling at Mach 2.3, the shockwave might hit the front of the craft at Mach 2.3, the wings at Mach 1.7, and the tail at Mach 1.5. Each shockwave creates different pressures and temperatures. Certain combinations of shockwaves can be dangerous for vehicles; the vehicle must withstand them all.

105. So long as the flight conditions, orientation, and vehicle shape remain the same, the shockwaves will hit the same parts of the airframe with the same aerodynamic forces and cause similar results.

106. Schmidle recounts that after the uncontrollable shaking on the April 2018, Virgin Galactic determined that flight at Mach 1.5-2 was dangerous for Unity. The uncontrollable shaking

would recur unless Virgin Galactic modified Unity to address it. The matter was discussed at Virgin Galactic Board Meetings.

107. To control the vibrations, Virgin Galactic developed a digital control system for its horizontal stabilizers. Digital control systems react more swiftly than humans and can automatically adjust for unusual flight forces over small time scales (such as flight control vibrations or instabilities). Virgin Galactic intended that the digital control system automatically control for vibrations, without the pilot's intervention.

108. Shifting from a manual to a digital control system is a major change. While digital control systems are generally understood, each is custom built. There are many ways digital control systems can cause failures. For example, unlike manual controls, such systems are electronic and may emit or be subject to electromagnetic interference ("EMI") to or from other on-board sources of electromagnetic radiation. Calibrating the system so that it translates the pilot's actions into proportionate movements of the controlled structures is crucial and difficult. While Virgin Galactic could do some testing on the ground, most of it requires test flights to assure proper coupling of the system components to pilot inputs.

109. The new digital control systems took a long time to properly install. Digital control systems use wires to transmit commands to the controlled parts. According to FE 1, the digital control system's wires did not fit into Unity and could not be made to fit Virgin Galactic's initial installation plan because engineers' drawings of Unity did not accurately represent Unity. Engineering would ask technicians to install wires in places that didn't exist, or which were configured completely differently than what the engineering order had described. When the technicians then tried to implement the engineering order, they found that Unity's actual structure looked nothing like what Engineering had pictured on the engineering order. Technicians would

report back to Engineering. Engineering would have to start again. So, fitting the digital control systems took months of formulating and discarding plans to make and fill holes in Unity to let the wires through.

110. According to FE 1, the digital control system also needed time-consuming adjustments to its telemetry are calibration.

111. Telemetry refers to transmitting vehicle flight and systems data. An airplane black box is an example of a telemetry recording device. Flight tests are useless unless the conditions under which the vehicle was flown are recorded for later analysis, so Virgin Galactic had to fix the digital control systems. Calibration refers to ensuring that measurements matched an objective standard, just as a scale must accurately report weight. Calibration is necessary to ensure that instruments respond precisely to sensory or mechanical inputs and directions. If the pilot commands the vehicle to roll two degrees left, the digital control system must ensure that the vehicle rolls two degrees left, not one degree or three degrees. But to do this, the input and feedback sensors in the digital system need to both function correctly (telemetry) and measure properly (calibration) to determine whether a two degree input yields a two degree response. Thus, both telemetry and calibration needed to be precise for Unity to fly.

112. According to FE 1, with “so many issues with the digital controls,” installing the digital control system took month after month after month, delaying Virgin Galactic’s flight plans. The problems were not resolved during FE 1’s tenure, which continued to December 2020.

113. Indeed, according to FE 9, as of July 2019, Eve was a patchwork of carbon composites that had been layered on over years. Engineers had requested, and continued to request, that Virgin Galactic replace certain parts. In order to keep to the flight schedule and generate

enthusiasm, Virgin Galactic pushed off the repairs to a later date. Because Virgin Galactic then did not have time to replace the parts, it made repairs.

114. Defendants knew of these issues. The November 2019 Memo's "Vehicle Development" section began by observing that "[w]e still have substantial work to do before going into commercial operation."

115. The Memo stated that Virgin Galactic had developed a digital control system and still had to test the digital control system and horizontal stabilizers together.

116. The Memo also stated that Virgin Galactic had not even completed the tests to show that the new horizontal stabilizer system physically fit together with its actuator.<sup>6</sup>

117. The Memo also stated that "*[a]s discussed*, we had an issue with the Hstabs during the February 2019 flight and so over the course of 2019 built a new set."

118. At the December 6, 2019 meeting, the Board was told that these repairs would take time and were necessary because Unity and Eve were not designed to support regular flights into space. The slides explained that:

- a. There was an "[e]xisting clash between Hstab and actuator that will need to be resolved prior to glide flight."
- b. Unity could not withstand flights to space: "[o]n-going structural analysis of Unity damage tolerance (DADT) is likely to require more modifications than originally planned."
- c. "Eve pylon structural analysis is on-going and could require modification or replacement before or early in commercial service." Indeed, Eve's pylon "has

---

<sup>6</sup> An actuator is the portion of the horizontal stabilizers which controls them.

certain design limitations and has been the subject of on-going structural analysis for long-term commercial service.”

119. The presentation’s Executive Summary concluded that “Unity Hstab structure and flight controls have taken longer than expected to install and verify functionality.” As set out above, the reason for the delays was that Virgin Galactic did not have accurate engineering drawings of Unity.

**C. Unity and Eve Were Prototypes That Would Never Be Capable of Regular Flights**

120. Defendants marketed Unity and Eve to investors as commercial grade vehicles. In announcing the Reverse Merger, Defendants boasted that “Unity, VG’s spaceship, was the first and remains the only vehicle *built for regular commercial service* to have put humans into space.” Defendants also presented investors with projections of their future operations anticipating that they would build more spaceships based on the Unity designs (the SpaceShipTwo, or SS2, design). Defendants misleadingly implied that Unity and Eve’s flight cadence (*i.e.*, how frequently they could fly) would match the new vehicles Virgin Galactic was building.

121. On slide 92 of a presentation delivered to investors and analysts in September 2019 (“September 2019 Presentation”), Defendants asserted that the flight rate for SS2 models would be 5 flights per month. On slide 94, Defendants asserted that Virgin Galactic would begin commercial operations in “June 2020”, “starting with one vehicle in service,” Unity. In the next bullet point, Defendants asserted that the vehicle (Unity) would have a “[m]odest flight rates at commercial start, scaling up to an ultimate anticipated flight rate of 5 per month in 2022 and thereafter.” In a separate bullet point, Defendants addressed the completion dates for SS2-2, SS2-3, and build time for SS2-4 and SS2-5. Thus, Defendants misleadingly suggested that Unity would

have the same flight cadence as brand-new spacecrafts. Before the Reverse Merger, in all their public statements, Defendants consistently referred to Unity and other SS2 model spaceships as “vehicles” whenever they discussed flight rates.

122. Defendants’ financial projections also reflected that Unity would fly at the same cadence as the new spaceships. Defendants assumed that the first new spaceship would be finished by late 2020, with its commercial flight beginning in 2021, so only Unity would fly in 2020. Defendants nonetheless assured investors that Unity would fly 16 times in the last 6 months of the year.

123. Unity’s ability to fly regular commercial flights was material to investors. With five flights a month for eleven months of the year, and five passengers per flight beginning in 2020, Unity was to carry 275 passengers per year in 2021 and “onwards.” Were each passenger to pay \$250,000, as Virgin Galactic assumed in its projections, Unity would generate revenues of \$68.75 million every year, about 66% of which would be pure profit. Indeed, Defendants projected \$21 million in 2020 revenue from Unity alone. Even after that, Unity would be one of only two anticipated SS2 spaceships in 2021. Thus, Unity would generate one half of Virgin Galactic’s 2021 revenues. By 2022, there would be three spaceships, with Unity thus generating one third of Virgin Galactic’s 2022 revenue. And even after that, Unity was to be one of five SS2 spaceships, thus accounting for one fifth of Virgin Galactic’s revenues beyond 2022.

124. Analysts repeated Virgin Galactic’s representations. In a November 21, 2019, report, UBS analysts recommended that investors buy Virgin Galactic’s shares because of its “near-term monopoly” on space tourism from Unity. In a November 21, 2019, report, Credit Suisse analysts stated that Unity could fly five times per month, attributing the estimate Virgin Galactic’s disclosures. In a December 9, 2019, report, Morgan Stanley analysts took a dimmer view of Virgin

Galactic's potential, estimating that it would have only three vehicles by 2023, but stating that each of these vehicles (including Unity) would fly 30 times that year. Even in an August 2020 report, Cowen analysts repeated that all SS2 model spaceships could reach five flights per month.

125. Yet because of facts known to Defendants that existed at the time of the Reverse Merger, Unity and Eve could never match new vehicles' flight cadence. They were prototypes that could never be strong enough for regular spaceflights. They each developed cracks after every flight. Even Eve, which Defendants asserted was essentially an airplane, spent about a month after flights grounded while Virgin Galactic repaired the cracks that had developed on the flight.

126. Defendants would never be able to address these problems because they did not have accurate engineering drawings of Unity and Eve. Defendants contracted with Scaled Composites to build Eve and 60% of Unity. While Scaled Composites handed over the vehicles, it did not hand over accurate or reliable engineering drawings. More, over the years, Virgin Galactic had modified the vehicles over and over and over again without documenting the changes. As a result, Virgin Galactic's engineering drawings for Unity and Eve did not accurately portray the vehicles.

127. Because Unity and Eve are built from carbon composites, these problems can never be remedied. Unlike metals, whose properties (such as tensile strength) are well known and determinable, properties of carbon composite materials depend on specifics of how many layers of which carbon materials were layered, how these layers were positioned, and how they were glued together. Short of tearing Unity and Eve apart, there is no way to determine their structure now.

*a. Defendants' admissions*

128. On a call to discuss Q4 2020 earnings, held on February 25, 2021, Defendants abruptly told investors that Unity had never been intended to fly regularly.

129. There, Colglazier admitted that Unity was just a prototype that “was built as our demonstrator vehicle” (*i.e.*, a prototype). It was “the one we modify along the way through flight tests.” As a result, Colglazier continued, it “has a pretty low rate as we talk about the frequency in which it flies”:

I don't know we [sic] have the ability to give you revenue quantification, but ***the difference between these, SpaceShipTwo, Unity—that's what we're flying now, was built as our demonstrator vehicle, that's how we've been working through the flight sciences and flight test program, and as such, it's the one we modify along the way through flight test, it has pretty low rate, as we talk about the frequency in which it flies***—the SpaceShipThree class, the first, which we showed that sneak peek earlier in the presentation as we said, they're built in a modular fashion. They're built to be maintained in a more reliable pace. They're still built in a relatively handcrafted form using the same techniques that we did for Unity, but with the learnings of that.

*b. Unity and Eve were fragile prototypes*

130. Virgin Galactic had hired Scaled Composites to help design prototypes, not commercial vehicles. But instead of using Scaled Composites' work product as inspiration for its own commercial vehicles, Virgin Galactic decided to use Unity and Eve as makeshift inferior “commercial” vehicles.

131. FE 6 explains that all of Scaled Composites' vehicles—including Enterprise, Eve, and Unity—were “research vehicles” that were never intended for commercial use. They were designed as, and meant to be, “one-off” vehicles—prototypes. Creating production vehicles had never been part of Scaled Composites' “mission.” Scaled Composites' vehicles—again including Enterprise, Eve, and Unity—were “home-built” with “very little” testing.

132. Based on FE 6's responsibility for actually building the vehicles, FE 6 reports that the contract clearly and specifically stated that the vehicles Scaled Composites delivered *were not meant to be used in a commercial capacity*. The prototypes were just engineering tools that Virgin Galactic would use for training and to facilitate their own design. Scaled Composites built the vehicles with the understanding that they were only prototypes: very quickly, without material testing, and to survive only a few flights.

133. According to FE 6, Virgin Galactic was struggling to live up to the schedule Branson had promised. Thus, Virgin Galactic used the vehicles in a commercial capacity because it did not have time to build its own structurally-sound, airworthy vehicles.

134. According to FE 9, because of its myriad problems, Eve would "never be like new." There was "no way to make [Eve] like a real airplane." Eve's limitations were why Virgin Galactic was attempting to build a second mothership.

135. FE 9 pointed out another reason the vehicles could not serve Virgin Galactic's commercial needs: "[Eve] as engineered is not going to last that long. It's too old." According to FE 9, Eve is "a bomb waiting to blow up because it is too old." Notably, FE 9 reports that examining Eve with a flashlight is enough to show that it is not airworthy and "not a good plane to fly at altitude", as FE 9 has performed such an examination. Eve is designed to "look cool and beautiful from a distance" but is really "kind of scary."

136. Former employees also report that Unity and Eve developed cracks after nearly every flight.

137. Virgin Galactic's teams are divided into engineers, technicians, and inspectors. The engineers design and model the vehicles' responses to stresses and order design modifications; the technicians implement the changes; and the inspectors determine whether the changes were

properly implemented, inspect the vehicles before and after every flight, and conduct additional inspections to find defects.

138. FE 2 and FE 7 (both engineers), FE 3 (a Virgin Galactic technician), and FE 1 (an inspector) all agreed that Eve developed cracks after *every* flight. FE 7 and FE 2 add that Unity also developed cracks after every flight. Indeed, FE 2 calls Unity a “flying band-aid.”

139. According to FE 3, the cracks were structural. About 90% of the cracks were in places where components had been bonded together with resin. For the most part, the cracks were not remediated during FE 3’s tenure. As a result, Eve’s wings were full of cracks.

140. Winged vehicles may develop cracks that are either parallel to the long side of the wing (“spanwise”) or perpendicular to it (“chordwise”). Different forces cause the spanwise and chordwise cracks, and they have different consequences. Spanwise cracks, in particular, can be caused by or induce an unpredictable, unstable feedback loop in the wings’ natural oscillations called flutter. As flutter oscillations get stronger and stronger, the wing could fail and fall off. Chordwise cracks, while less dangerous, could tend to show that forces that bent the wings were overstressing its skin.

141. According to FE 2 and FE 7, many of the cracks that appeared on Unity were especially dangerous because they were spanwise.

142. According to FE 7, the cracks on Unity were always obvious. Moreover, Virgin Galactic employees would visually inspect Unity in the hangar after every flight.<sup>7</sup>

143. FE 7 also reports that technicians were always working on or repairing Eve’s wings because of cracks. The cracks appeared in key structural components, including spars. “Every time

---

<sup>7</sup> Schmidle reports that after the February 2019 flight, both Stucky and Virgin Galactic Safety Director Todd Ericson were watching Unity as it was wheeled into the hangar.

[Eve] flew” there were “extensive repairs” required afterwards.

144. FE 9 describes the process of repairing Eve after its flights during his tenure, which overlaps with most of the Class Period. Virgin Galactic inspected Eve for cracks after every flight. Inspection findings were then passed on to Engineering which would figure out which cracks needed to be fixed immediately. Mechanics would then fix the cracks by laying down new fiber and also sometimes applying aluminum sheet metal over the affected area. By the time FE 9 worked for Virgin Galactic, Eve was a patchwork of handmade repairs layered over its original parts. Yet even after being “fixed” an area might crack again after a few flights. FE 9 worked on Eve’s “armpit,” where the wings and the body of the aircraft merged. According to FE 9, Eve’s “armpit,” just one part of the vehicle, cracked every two to three flights. Eve itself cracked after every flight. Fixing Eve’s cracks took about a month on average, and the fixes always increased Eve’s weight.

145. Before FE 8 and FE 1, Virgin Galactic never attempted to determine why cracks formed on Eve’s wings. During their tenures, Virgin Galactic conducted a “huge study”, which determined that when the resin is over a certain thickness, it will crack, because it is “extremely brittle.”

146. According to FE 9, Eve was so fragile that it could only fly in “perfect weather conditions.” Any rain or heavy wind could cause Eve to crash, yet another reason why Eve was not suited to commercial operations.

147. Further, according to FE 9, Virgin Galactic used repairs as a poor substitute for replacement. Engineers wanted to replace many parts of Unity and Eve, including but not limited to Eve’s pylon, but there was never any time because of Virgin Galactic’s aggressive flight

schedule. Thus, Virgin Galactic repaired the existing deficient parts instead, putting off replacement to another day.

*c. Virgin Galactic did not have accurate engineering drawings*

148. Unity and Eve also cannot be turned into fully commercial vehicles because Defendants lack accurate engineering drawings.

149. Engineering drawings are detailed representations of aerospace vehicles as they actually exist. Drawings provide crucial information such as every part in the vehicle, and their exact thickness, composition, specifications, dimensions, and tolerances, so that the parts can be manufactured with minimal variation. Engineers use these drawings to model and define the vehicles' performance, determine when parts need to be replaced, and understand what needs to be changed and how, and what does not. Virgin Galactic would also use these drawings to create parts to subject to lab testing to identify any weaknesses or deficiencies or test them in new conditions created when Virgin Galactic altered the vehicles.

150. Engineers also supplement detailed engineering drawings with literature explaining why particular parts are made in particular ways and installed in particular places along with the engineering calculations and analyses to support the rationale. This literature also explains the requirements the parts must meet, and the normal and maximum rigors they are expected to withstand, alerting engineers that they may need to re-examine or redesign the part if other aspects of the vehicle (*e.g.*, its weight or anticipated speed) change.

151. Scaled Composites built Eve and most of Unity. When Virgin Galactic severed the relationship, Scaled Composites turned over some materials, leaving The Spaceship Company to complete Unity.

152. According to FE 6, Scaled Composites was only obligated to deliver the vehicles themselves, along with some limited paperwork and test data. Scaled Composites had no obligation to deliver engineering drawings or documentation, and it did not.

153. According to FE 3 and FE 8, while Virgin Galactic and The Spaceship Company completed Unity, they did so with what they could understand of Scaled Composites' drawings.

154. According to FE 1, the Unity drawings that Scaled Composites sent to The Spaceship Company and which it in turn provided to Virgin Galactic were minimal and flimsy. Nor did Scaled Composites turn over the detailed literature that would explain why parts were designed a certain way.

155. While Scaled Composites built Eve in its entirety, FE 3 reports that Scaled Composites did not turn over detailed engineering drawings of Eve, either.

156. According to FE 3, by 2017, there was "bad blood" between Scaled Composites and Virgin Galactic. Virgin Galactic had unfairly blamed Scaled Composites (in its view) for the 2014 accident. So, according to FE 3, there was "no significant company-to-company communication."

157. What documentation there existed bore signs that it was incomplete or unreliable, or both. FE 3, FE 7, and FE 8 all reported that some of the final design drawings for Unity's and Eve's parts were on napkins or done in crayon. According to FE 8, in some cases, the napkins were stained with coffee. In others, they were stained with beer.

158. According to FE 7 and FE 8 the napkin or crayon-drawn parts had never even been converted to formal drawings, let alone properly tested.

159. According to FE 9, Eve's design is based on "scribbled, handwritten notes," with insufficient specifications, which Virgin Galactic never "translat[ed]" into a real, properly-

documented design. Scaled Composites' drawings were in handwritten notebooks, some of which had been scanned into pdfs, some of which had not. These drawings looked like something out of the 1980's. Even in 2021, engineers like FE 9 would have to review photocopies of the handwritten design notes and try to decipher them in order to improve or fix the vehicles. Scaled Composites had never produced any manipulable drawings, such as CAD designs, or Word or Excel files. Further, the drawings were rudimentary, as they were "rough sketches" rather than "a real blueprint drawing" and did not contain important information like how to join components, lay out plies, or even how to make the parts.

160. According to FE 3, Virgin Galactic employees had to put "blind faith" in a napkin drawing, "go by what it says," hope it was correct, and then wait to find out if it had been.

161. And indeed, FE 7 reports that Scaled Composites' drawings frequently lacked enough detail for Virgin Galactic to understand the part's dimensions or specifications. The drawings sometimes had so little detail that it was unclear what the part was even supposed to look like. At that point, "we were just lost."

162. Even if Virgin Galactic could discern a part's actual dimensions and specifications, employees could not know why a change was made. According to FE 7, it would be unclear whether a part had been replaced because it was obsolete, that something was being added to the part to, say, increase rigidity, or that the part had failed.

163. According to Mr. Meholic, companies must know why a part was changed to know what to do if something happens or if the company wants to change the vehicle's design. If a part failed because it was too weak, for example, the company should ensure that when it changes other things in the vehicle, it does not compromise that initial improvement. The company should also consider the conditions under which the part failed to determine whether it failed under normal

conditions, or in excess of requirements. If the part was installed to meet a specific requirement, then the company might consider examining the requirements to ensure they are still needed and that the design meets those needs.

164. With little or no documentation, FE 7 reports, Virgin Galactic often had to perform custom-made stress tests to reverse engineer the vehicles' configuration and capabilities or that of specific components. The process wasted enormous resources and time, as engineers had to devise and implement novel one-off tests and could not reconstruct all the information that would have been set out in the engineering drawings or the accompanying documentation.

165. FE 3 reports one instance in which it took years for Virgin Galactic to discover that a key component required for the structural integrity of Eve's wings did not exist. The wing's skeleton was built from spars that were laid parallel to the long side of the wing, and ribs, which are laid perpendicular to the long side. Eve's documentation, which informed stress modeling, reported that the spars created a box-like structure. The box structure was supposedly composed of two main horizontal caps (upper and lower) and two supporting vertical webs, called shear webs. The shear webs provided rigidity to the spars.

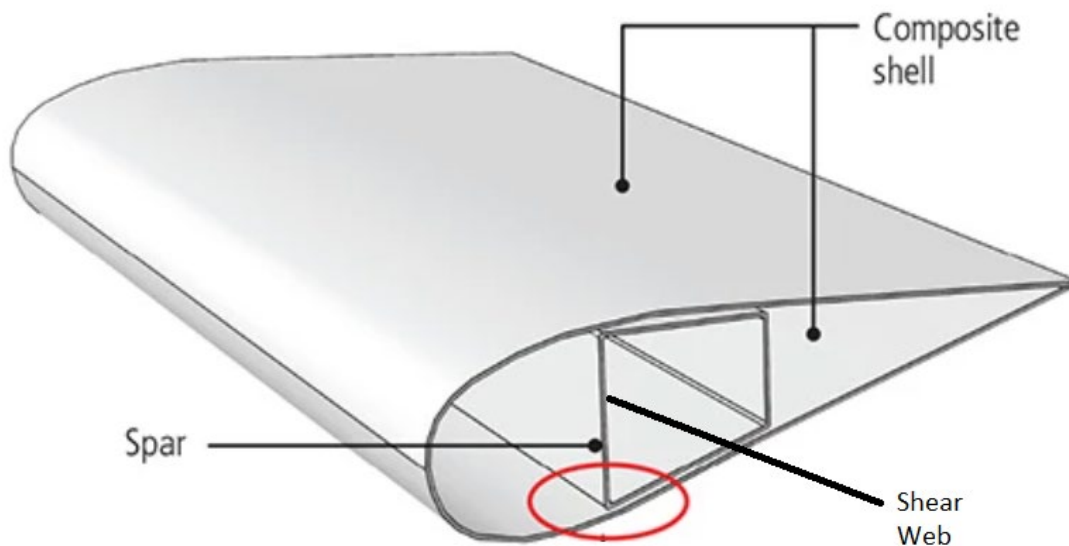

166. According to FE 3, Eve was flown two or three times shortly after the October 2014 crash. Then, beginning January 2015, Eve spent ten to twelve months in the shop while Virgin Galactic engineers and technicians strengthened its wings.

167. The work complete, Virgin Galactic took Eve on at least six flights in 2016.

168. Yet according to FE 3, it took until 2017 for Virgin Galactic to discover that there was *only one* supporting shear web. There was no box-like structure. When they learned that the wings' engineering drawings included a part that was not there, Virgin Galactic's engineers reviewed the documents that Scaled Composites had dumped on them. The engineers discovered some pictures of the wing taken after its installation. In the pictures, the wings indeed only had one shear web.

169. This was just one of Scaled Composites' many undocumented changes. According to FE 3, it happened "all the time" that Scaled Composites' drawings documented parts that were not actually in Unity or Eve. Indeed, Scaled Composites had made "a million [undocumented] changes" so that Eve is "nothing like it was supposed to be." The engineers had difficulty doing stress modelling and sometimes it was a "wild guess" whether the repairs they ordered would be strong enough.

170. Virgin Galactic still had not determined the vehicles' actual configuration in 2021. According to FE 8, there were things "we thought" were in the vehicles that were not, and vice versa. And sometimes Virgin Galactic knew that a part was there but had no idea why. For example, there is a piece of metal in Unity's wings whose purpose no one at Virgin Galactic knows. The part did not appear to perform any structural functions. Virgin Galactic thought of removing it, but it would take a lot of work and would likely cause damage in the process, so it was retained.

171. Virgin Galactic's own subsequent undocumented changes created even more uncertainty.

172. Virgin Galactic's technicians and engineers used software called Ultramain to keep track of Engineering's assignments and the status of the shuttle. According to FE 2, an engineer, engineers first drafted engineering orders, which appeared as redlines to existing drawings.

173. FE 5, who worked in maintenance control, then took these engineering drawings and created instructions for technicians.

174. FE 3, a technician, corroborates FE 2's and FE 5's account. FE 3 reports that once an engineer signed off on an engineering order, it was sent to maintenance control (i.e., FE 5's office). FE 3 adds that when maintenance control translated the engineering order to specific steps, it was published on Ultramain. Technicians then used iPads to access Ultramain and obtain their assignments to complete the engineering order.

175. The system was a chaotic mess that resulted in undocumented changes. According to FE 3, Ultramain is designed for commercial aircraft whose maintenance consists of going down a well-established checklist set out in a manual. Yet Virgin Galactic was building a prototype that changed rapidly.

176. According to FE 3, Ultramain could not accommodate changes in engineering orders. Once an engineer signed off on an engineering order, the task was "published" onto Ultramain to be parceled out. After the engineering order was published, it could no longer be edited to add steps. If Engineering changed its mind, or if technicians told Engineering the engineering order could or should not be completed, Engineering had to create a redline and publish it as a new engineering order. Publishing a new engineering order wiped the old

engineering order from the system. If, as was usually the case, technicians had already completed a subtask and signed-off on it, their sign-off did not carry over onto the redline.

177. Virgin Galactic's engineering orders were very complicated and involved many engineers. According to FE 3, engineering orders commonly required hundreds of work hours from ten technicians. Here again, Ultramain was not suitable for Virgin Galactic's operations. When a redline of a complicated task erased previous work, lead technicians had to contact every team member to determine whether they had signed off on particular steps. Ultramain would reveal that a technician was working on a particular task, but not which technician.

178. Thus, the lead technician would not know for sure which technicians had completed tasks on a particular engineering order and could miss tasks. Work that had been ordered was often never completed without anyone realizing that it had not been.

179. Virgin Galactic's maintenance crews also regularly completed work that had not been ordered. According to FE 3, for example, engineering orders sometimes called for technicians to apply one layer of resin. If the technician applied a layer of resin and signed off on the task, but that technician's sign off was lost because Engineering entered a redline of the engineering order, then an additional layer of resin would probably be applied. That additional layer would not be documented in the vehicle's engineering drawings, which would instead reflect that there was only one additional layer of resin, when in fact there were two. Mistakenly applying two layers of resin instead of one "absolutely happened." FE 1 recalls that as a result, in some cases, the number of layers might be anywhere from 50 to 200 as far as Virgin Galactic knew.

180. And even if the lead technician did find all technicians and they accurately reported their tasks, Ultramain still did not provide sufficient information. According to FE 3, technicians were supposed to write the name, lot number, serial number, and expiration date of the part they

installed or the resin they used in fulfilling an engineering order, in a narrative section on Ultramain. This lets Virgin Galactic know when a part must be replaced. But publishing a revision erased technician's notes of the name, lot number, serial number, and expiration date of any part that had been installed. The information was lost unless the technicians had written down the narrative section elsewhere or somehow remembered exactly what tasks they had completed and what components they had used. After multiple rounds of modifications to engineering orders, there was no record of what parts had been installed or the parts' expiration dates.

181. FE 2 reports, from Engineering, that engineers could not access engineering orders after a redline was published, either. Further, technicians sometimes discovered problems with the components on the spacecraft and did not document the preventative maintenance they then conducted to address the issue. Technicians then did not always update Ultramain when they replaced a component. As a result, Engineering did not understand the vehicles' actual condition and configuration.

182. FE 2 also reports on the information lost. Virgin Galactic's engineers used CAD ("computer-aided design") software to keep track of designs and parts. Both CAD and Ultramain kept track of components and serial numbers. But the two databases were inconsistent. The components' serial numbers in the two databases frequently did not match up. In other instances, they were missing entirely. FE 2 was only told of a discrepancy when the mismatched serial numbers created safety issues; still, FE 2 was told of discrepancies weekly.

183. This created substantial safety risks. According to FE 2, some of Unity's parts are "flight cycle dependent," meaning that they could only be flown so many times before they needed replacement or inspection. Yet Virgin Galactic's engineers frequently did not know how old Unity's components were.

184. According to FE 5, because there were so many changes and redlines, Virgin Galactic personnel could pull the original engineering definitions from the system but would instead have to scavenge for the correct, newest redline version. Virgin Galactic made “constant changes” to the engineering drawings.

185. FE 1, who headed Virgin Galactic’s inspection teams, corroborates FE 3’s account. According to FE 1, Virgin Galactic stored engineering drawings of its vehicles on folders accessible through SharePoint. The engineering drawings were meant to reflect the vehicles’ current configuration, including redlines, and all pending work orders. But instead of having one drawing for Unity that reflected all changes in redlines, the company would often instead simply create new drawings. FE 1 estimates that there were 500 re-drawings just of Unity’s cabin’s interior. Further, in many cases, a new drawing or redline would be released though it had not actually been approved by Engineering. Some of these drawings and redlines were never approved, but technicians and inspectors did not know that Engineering retracted the drawings.

186. According to FE 8, Virgin Galactic named successive drawings like software companies named versions of their product. The first drawing is numbered 1, the second 2, and so on. The first redline to the first drawing is numbered 1.A the second redline to the first drawing is 1.B, the first redline to the second drawing is 2.A, and so on. FE 1 and sometimes Engineering itself would not know the correct revision. For example, they might not know whether the latest version was 1.F or 2. Further, there might be two different versions of 1.F, with none of engineers, technicians, or inspectors confident about which version to use as the basis for 1.G or 2.

187. Even to find the candidates for latest version, FE 1 had to engage in “data mining” in the folder. FE 1 estimates that about 25% of the time, it was impossible to tell which revision was the correct one because of unreliable revision numbering. In the remaining cases, FE 1 and

FE 1's team were never certain that their data mining had unearthed the correct drawing. If they were lucky, "someone came down screaming" if they used the wrong engineering revision to perform maintenance. But it was relatively common for the engineers not to spot the discrepancy when the technicians used the wrong drawing to upgrade the vehicle or install a component. As a result, it was "100%" certain the inspection staff missed deviations and therefore that the vehicle's drawings and document "did not match the reality". Further, the problem *worsened* during FE 1's tenure of summer 2019 through December 2020.

188. FE 10 reports that the problem was compounded because Virgin Galactic used three overlapping and mutually inconsistent databases to store engineering information, including maintenance tasks. Virgin Galactic used Ultramain for several functions including parts, procurement, and flight hardware configuration changes, an Agile database as a repository of as-designed engineering, and an Oracle system to store engineering write-ups of modifications. The procedures and information set out in these databases were different and mutually inconsistent. As a result, Virgin Galactic had multiple procedures for how to do the same things that were often all different and mutually inconsistent.

189. Similarly, FE 9 reports that there were "pages and pages" of procedures for making any given repair, but there were numerous versions and "they were all different."

190. FE 4 identifies a remarkable instance of sloppy documentation. One day, FE 4 was trying unsuccessfully to install an elevon on Unity. FE 4 had relied on engineering drawings to install hardware to keep a pin in place. Seeing FE 4 struggling, another technician told FE 4 that Virgin Galactic had modified the part so that the amount of force needed to move it had doubled or even tripled. The change had not been logged or documented. Instead, an email had been sent out to certain employees (but not to FE 4).

191. FE 1 called Virgin Galactic's documentation of its systems, maintenance, and repairs "loosey-goosey." FE 1 cites additional myriad issues and discrepancies in the maintenance documentation. These included the same deficiencies described by FE 2 and FE 3 above, such as failing to document what materials had been used, their serial numbers, or expiry dates, but also not recording the dimensions of a given item that had been repaired.

192. The result was chaos. FE 1 reports that especially when dealing with the cabin's interior, no one seemed to have any idea what the latest design was. As a result, Engineering would enter nonsense engineering orders, like requests to attach brackets in locations that did not exist.

193. FE 7 identified similar problems. According to FE 7, Virgin Galactic used molds to make its own composite parts. Virgin Galactic should have had, but did not have, a documented "process spec" for each mold as well as documentation for the materials that were being used. Moreover, before around 2016, Virgin Galactic made parts such that technicians had to break the mold to get the part. Because every part was made with a different mold, even ostensibly identical parts were actually different.

194. According to FE 7, Virgin Galactic did eventually change its component manufacturing process. But Virgin Galactic never replaced the legacy non-standard parts that had been installed in Unity and Eve. These non-standard parts had been used in the primary structures of the vehicles, so they are permanently integrated into the vehicle. They are there to this day.

195. According to FE 7, Virgin Galactic did not purge the non-standard legacy parts that had not yet been installed. Instead, Virgin Galactic kept them in inventory and slowly consumed them on Unity and Eve. So there were "a lot of fit issues" between new standardized components and the legacy non-standard components.

196. FE 2 cites one example of a near disaster. In a 2018 post-flight inspection that resembles a sonogram, Virgin Galactic discovered that the resin in some of Unity's parts had developed large internal voids. The voids turned out to be large cracks that opened during the flight. The subsequent investigation determined that the resin that held Unity's frame together had been left out too long in open air before being used, resulting in a process called amine blushing. Just as glue left out too long loses some of its effect, amine blushing causes resin to lose some of its bonding properties.

197. According to FE 2, Virgin Galactic was "extremely lucky" the structure did not fail. The cracks could easily have become large enough to cause an aerodynamic rip similar to the 2014 accident, which would have destroyed Unity and killed everyone on board. The discovery "shook our boots".

198. Schmidle corroborates FE 2's account. He reports that Virgin Galactic made the discovery in September or October 2018. He reports (in Schmidle's words) that the discovery:

[M]ade Stucky uneasy. He was okay flying an imperfect ship if he knew where the imperfections were. But on his spectrum of real versus imagined risks, a bad bond qualified as very real. He shuddered to think about charging through the atmosphere at twice the speed of sound if suddenly one of those air bubbles in the bond popped and caused the boom to shear off.

199. Indeed, Virgin Galactic had been aware that the weak bonds were potentially catastrophic for five years but had not resolved the problem. Schmidle quotes 2013 correspondence from Defendant Moses:

"Heads up", Moses had informed the management team, back in 2013. "We are finding some deeper issues, including the upper wing skin being debonded in places from the wing spar."

200. To keep to the schedule, Virgin Galactic did not inspect every bond, as Stucky suggested. Instead, they only examined one particular location. In Schmidle's words:

Stucky suggested the engineers test every bond on the ship by slapping industrial-size suction cups on the outer skins and then trying to pull them off. His recommendation was deemed indelicate. Instead, the maintainers cut panels into the flawed boom, so, with the aid of borescopes, the techs, working blind in narrow crevasses with sometimes only an arm inside the ship, could track their progress on a flat-screen monitor.

201. According to FE 9, Virgin Galactic's poor documentation caused lengthy delays. With no accurate engineering drawings, Virgin Galactic's engineers were delayed by trying to figure out how to make repairs or improvements. The vehicles would remain grounded until Virgin Galactic's engineers could create a new procedure to accomplish something that in functional companies would have been documented in engineering drawings and accompanying literature. Moreover, the lack of documentation meant that Virgin Galactic depended on engineers who had been around when all the design decisions were made—and, as FE 9 noted, there were very few of them.

202. Thus, reasonable investors who assumed Virgin Galactic was a functional company were wrong.

*d. Because Unity and Eve are made of carbon composite, Virgin Galactic will never be able to generate accurate engineering drawings*

203. Unity and Eve are made substantially of carbon composite materials. Composites generally consist of layers of carbon fabric and other materials (such as Kevlar or fiberglass fabric) that are stacked atop one another and adhered together with glue-like resins. The number of fiber and resin layers, the specific composition of each layer, the orientation of each layer, and the number of resin coats, are all necessary to determine each part's size and properties. Thus, unlike vehicles made of metals, it is difficult to determine the properties of vehicles made of composite fiber without accurate engineering drawings.

204. According to Mr. Meholic, there was likely no non-intrusive way of determining Unity or Eve's structure. To do so, Virgin Galactic would have to cut a sample from the

component, but doing so would impact the component's structural integrity. Virgin Galactic had not addressed this problem when FE 1 left Virgin Galactic in December 2020.

205. Engineers use mathematical models and lab testing of duplicate parts to determine the tolerance and durability of Unity and Eve's parts. If the engineering drawings are inaccurate compared to the as-built hardware, the tests could still leave questions about whether the vehicles, like Unity and Eve, are safe. With no accurate engineering drawings, time-consuming tests after every flight are all but unavoidable.

## **VI. LOSS CAUSATION**

206. During the Class Period, Defendants engaged in a scheme to deceive the market and a course of conduct that artificially inflated the price of Virgin Galactic's common stock. Defendants' conduct, moreover, operated as a fraud or deceit on Class Period purchasers of the Company's common stock by failing to disclose, and misrepresenting, the adverse facts detailed herein. As Defendants' prior misrepresentations and fraudulent conduct were disclosed and became apparent to the market, the price of the Company's common stock declined significantly as the prior artificial inflation dissipated from the Company's stock price. As alleged herein, corrective disclosures revealed previously undisclosed truths that caused a decline in the Company's stock price, and the materialization of concealed risks occurred that caused a decline in the Company's stock price through the events alleged that constructively disclosed the fraud attributable to such concealed risks.

### *a. August 4, 2020*

207. After the close of trading on August 3, 2020, Virgin Galactic issued a press release announcing its Q2 2020 earnings. In the press release, the Company announced that Branson's flight would be delayed from 2020 to 2021:

Virgin Galactic expects to advance to the next phase of its test flight program with its first powered spaceflight from Spaceport America this fall, with two test pilots in the cockpit. Virgin Galactic then expects to conduct a second powered space flight from Spaceport America, with a crew of two test pilots in the cockpit and four mission specialists in the cabin. Assuming both flights demonstrate the expected results, Virgin Galactic anticipates Sir Richard Branson's flight to occur in the first quarter of 2021.

208. On August 4, 2020, Virgin Galactic's stock price fell from its previous closing price of \$24.02 to close at \$20.72, down \$3.30 (13.7%) on the news.

209. The delay of Branson's flight constituted a materialization of the risks concealed by Defendants' statements touting the February 2019 flight, which suggested that remaining technical issues were relatively minor. Defendants concealed the destruction of a critical component of Unity that led to considerable delays in Virgin Galactic's testing and commercialization.

210. Further, the August 3, 2020, delay was a materialization of the risks concealed by Defendants' statements that Unity was complete. Even as Defendants made their statements, Unity was grounded because, at a minimum, it had neither horizontal stabilizers nor flight control systems. Unity's flights were delayed because Virgin Galactic had to design, build, install, and test these new systems.

*b. December 14, 2020*

211. When designing and testing new aerospace vehicles, new parts must be designed, built from scratch, installed, and then tested. Each of these steps creates substantial risks of delay that the Company does not face if the vehicle had already been completed or merely required upgrades. Thus, Defendants' false statements regarding Eve and Unity concealed the risks of substantial delay while Virgin Galactic designed, built, installed, and tested new parts. In

particular, Defendants’ misrepresentations concealed the risk that these new parts, once installed, would create problems.

212. In 2018, Defendants learned that Unity shook uncontrollably between Mach 1.5 and 2. Defendants had to modify Unity to address it. They chose to replace Unity’s manual system with a digital control system, which would automatically adjust to control the shaking. The modifications took place in 2019/2020

213. Virgin Galactic installed the flight control computer, which controlled the digital control system, right next to the computer that controlled Unity’s rocket motor.

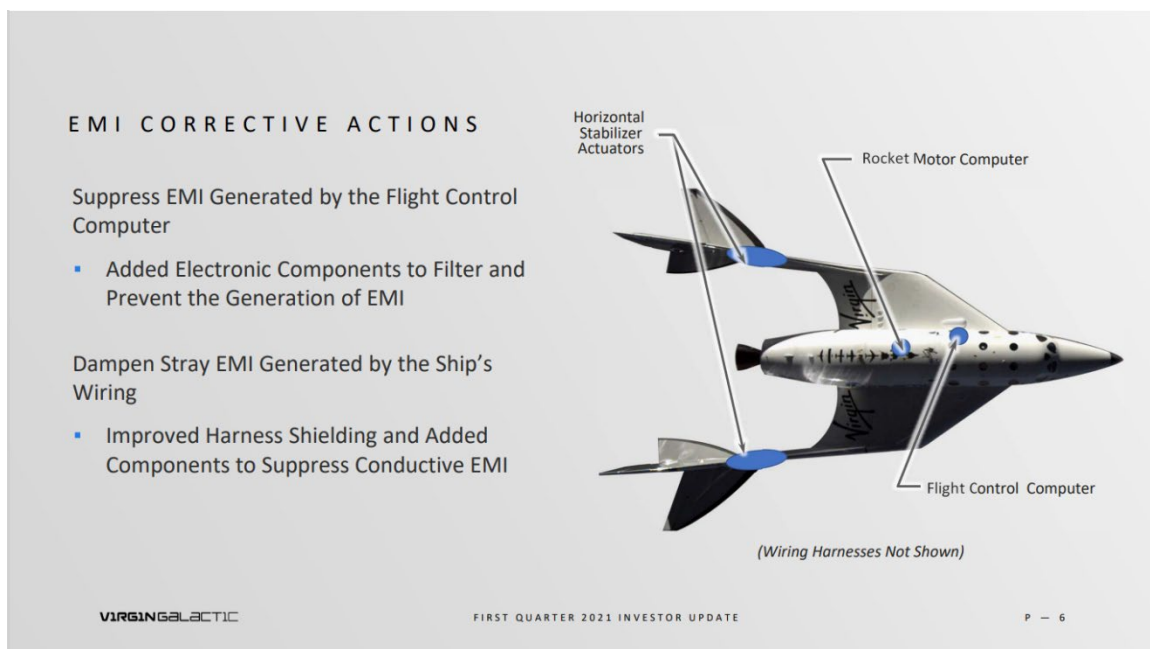

214. Unlike Unity’s old manual control system, the new digital control system emitted electromagnetic radiation.

215. Electromagnetic emissions from one system can interfere with other electronics, called electromagnetic interference (“EMI”). Because the digital control system’s control computer and rocket motor controller were next to each other, the EMI could cause the rocket motor controller to lose its connection with the rocket motor. And on the first powered flight after February 2019, it did.

216. Virgin Galactic scheduled its first New Mexico powered flight for Saturday, December 12, 2020. The Company represented that this flight would be the last before Branson's flight. During the flight, the rocket never started and the flight automatically aborted. Unity's pilot then glided the shuttle down to landing.

217. Although not disclosed at the time, the new digital control system had caused EMI, which caused the rocket motor controller to lose connection with the rockets, which, in turn, automatically shut off the rockets.

218. On Monday December 14, 2020, Virgin Galactic's stock price fell from its previous close of \$32.04 to close at \$26.47, down \$5.57 (17.4%), damaging investors. The failure of Unity's rocket to function represented the materialization of concealed risks regarding EMI that were constructively disclosed by the abortion of the flight which, in turn, caused the decline in the Company's stock price.

*c. February 1, 2021*

219. After the close of trading on February 1, 2021, the *Washington Post* published an article disclosing that Virgin Galactic's February 2019 flight had nearly ended in three deaths:

Richard Branson's Virgin Galactic had just had its second successful flight to the edge of space, a daring mission that it said put it one step closer to finally flying tourists and making it the "world's first commercial spaceline."

But when the ground crew wheeled the suborbital spacecraft back into the hangar, company officials discovered that a seal running along a stabilizer on the wing designed to keep the space plane flying straight had come undone — a potentially serious safety hazard.

"The structural integrity of the entire stabilizer was compromised," Todd Ericson, a test pilot who also served as a vice president for safety and test, said, according to a soon-to-be-published book. ***"I don't know how we didn't lose the vehicle and kill three people."***

This previously unreported account of the flight in February 2019 is contained in "Test Gods: Virgin Galactic and the Making of a Modern Astronaut" by New

Yorker magazine journalist Nicholas Schmidle, who spent almost four years embedded with the company.

\* \* \* \* \*

In the book, Schmidle wrote that the “seal had disbonded on the way up, as the pressure increased with nowhere to vent,” ultimately leaving a “wide gap running along the trailing edge of the right h-stab,” or horizontal stabilizer. When Mike Moses, Virgin Galactic’s president, missions and safety, saw the gap, “he felt his stomach drop,” Schmidle reported. Moses’s wife, Beth Moses, Virgin’s chief astronaut instructor, had been on the flight.

\* \* \* \* \*

Virgin Galactic “tried to keep the h-stab problem quiet, worried that it might spook customers,” Schmidle wrote. That stance concerned Ericson, a former military test pilot who had served as the safety chief at the Air Force Test Flight Center before coming to Virgin Galactic in December 2014, according to his LinkedIn profile.

“This should have been a Come-to-Jesus Moment, not the kind of thing you brush under the rug,” Ericson said, according to the book. Ericson informed the company in June 2019 that he was stepping down as vice president of safety, which concerned George Whitesides, then the company’s CEO, who Schmidle wrote was suddenly faced with the prospect that “his vice president of safety was resigning because he’d lost confidence in the safety regime.”

\* \* \* \* \*

[In an interview on February 1, Defendant Moses] said the problem occurred when thermal protection coating was applied incorrectly and ended up blocking vents intended to allow air inside the stabilizer to escape as the atmospheric pressure decreased outside the craft as it flew higher.

“The design of the h-stab wasn’t really an issue there,” Moses said. “It was an error that occurred in processing on the ground. *Clearly a problem, right? Not something that should be allowed to happen and something we clearly needed to address.*”

\* \* \* \* \*

*At the moment the problem was discovered the teams were concerned, even emotional. “The reaction is, ‘Wow, what was that? How could that happen?’”* he said. But investigating the issue and finding the problem “gives us pretty high confidence in our design and our performance on the changes we made since,” he said.

\* \* \* \* \*

After the February 2019 flight, Virgin Galactic grounded the vehicle and began redesigning the stabilizer and hired a contractor to “build a new one from scratch, out of metal,” Schmidle reported, instead of the composite carbon fiber used previously.

220. On February 2, 2021, Virgin Galactic’s stock price fell immediately upon the opening of the trading session. By the close of the session, it had fallen to \$48.58, down \$5.21 (9.6%) from its previous close of \$53.79, damaging investors.

221. The revelations in the February 1, 2021 *Washington Post* article constituted a materialization of the risks concealed by Defendants’ statements touting the February 2019 flight, which suggested that remaining technical issues were relatively minor. Defendants concealed the destruction of a critical component of *Unity* that led to considerable delays in Virgin Galactic’s testing and commercialization efforts.

*d. February 25, 2021*

222. On February 25, 2021, Virgin Galactic held a call to discuss its Q420 earnings. On the call, Colglazier admitted that *Unity* was just a prototype that “was built as our demonstrator vehicle.” As a result, Colglazier continued, it “has a pretty low rate as we talk about the frequency in which it flies.”

223. The change surprised analysts who covered Virgin Galactic:

- a. On February 26, 2021, Credit Suisse analysts published a report noting that it had changed its financial models for Virgin Galactic. The analysts explained that “since *Unity* is now viewed more as a prototype vehicle, we do not see it flying in commercial service as frequently as before.” The analysts also lowered their estimate of 2021 revenues from \$26.4 million to \$5.5 million, and their estimate of 2022 revenues from \$213.5 million to \$66.0 million.

- b. On February 26, 2021, UBS analysts published a report reducing their estimate of 2021 revenues from \$21.0 million to \$4.0 million and their estimate of 2022 revenues from \$150.0 million to \$85.0 million.
- c. On March 11, 2021, Morgan Stanley analysts published a report reducing their estimate of the number of passengers Virgin Galactic would fly in 2022 from 180 to 60.

224. On February 26, Virgin Galactic's stock price fell from its previous close of \$42.24 to close at \$37.23, down \$5.01 (11.8%), damaging investors.

*e. September 2-3, 2021*

225. Virgin Galactic had four flights on its schedule for the summer of 2021. The first flight, scheduled for May, was the re-scheduled December 2020 test flight. The second would take a crew to space. The third would take Defendant Branson to space, along with three others. The fourth would take Italian Air Force personnel to space.

226. On May 22, 2021, Virgin Galactic conducted its first powered flight—and its first spaceflight—since its disastrous February 2019 flight.

227. On June 6, 2021, Virgin Galactic competitor Blue Origin announced that it would take its founder and billionaire Jeff Bezos to space on July 20, 2021.

228. Then, on July 1, 2021, Virgin Galactic announced that it would take Branson to space on July 11, nine days before Bezos's flight.

229. On July 11, 2021, Virgin Galactic issued a press release concerning Unity's first fully-crewed space flight, dubbed Unity 22, on which Branson was a passenger. The press release quoted Defendant Colglazier as saying:

***Today is a landmark achievement for the Company and a historic moment for the new commercial space industry. With each successful mission we are paving the***

*way for the next generation of astronauts.* I want to thank our talented team, including our pilots and crew, whose dedication and commitment made today possible. They are helping open the door for greater access to space – so it can be for the many and not just for the few.

230. Also on July 11, 2021, Defendant Colglazier appeared on Bloomberg Markets' *The Close*, where he stated:

**Q:** A lot of the event was about Richard, you know, Richard was front and center, but you know, as the CEO of the commercial business, what does today represent for you? What does it allow you to do?

**DEFENDANT COLGLAZIER:** Well, two things. I think for the world, it allows us to show that something people never thought was gonna happen in their lifetimes is actually happening now. *The ability for regular people to be able to go to space and it will take years to really get the scale of it up but I think we showed today what that is going to be like and a taste of that going forward.* So that was huge. And then at a business level, this was one of the remaining flight tests that we need to do as we move into commercial service. So we've got two more. *This one was perfect.*

\* \* \* \* \*

**Q:** Was Sunday's event about selling tickets? Was that really what it was about?

**DEFENDANT COLGLAZIER:** *This event was about showcasing to the world what this Virgin Galactic experience is going to be. And this event was part of our incredible safety diligent program to make sure that we go step-by-step so that when we do open this up for commercial service, we've done all that needs to be done. So it's amazing and anchored in safety experience and that's what today was about.*

231. Bloomberg Markets also interviewed Defendant Branson:

**Q:** Well, what does it mean for the company? There was some risk involved. I'm sure that some of your staff looking at me right now were nervous at points.

**DEFENDANT BRANSON:** *Well, look, the company is 17 years, they've had a number of flawless flights. They've never had any major, major technical issues even, you know, in the last 17 years and this was absolutely and utterly flawless.*

232. Based upon Defendants' statements, on July 12, 2021, a Canaccord Genuity analyst issued a report stating that "[t]he July 11 flight with Sir Richard Branson was as successful as the company could have hoped."

233. It took little time for both Virgin Galactic and Defendant Branson to cash in.

234. Between July 12 and 16, 2021, Virgin Galactic sold \$500.0 million of shares in open market transactions.

235. From August 10 through August 12, 2021, Branson sold 10.4 million shares for \$299.9 million. Branson sold every share he was entitled to sell; his remaining shares were subject to a lockup agreement.

236. Yet, at the time of the sales, Defendants knew material nonpublic information: Branson's flight had dangerously strayed from its landing cone and FAA airspace, thus imperiling the lives of its passengers.

237. Unity does not use any of its fuel to position itself for landing. Rather, it burns all its fuel to reach 50 miles above the Earth's surface. After it reaches its apogee, its highest point, it glides to a landing, using only its own momentum and steering instruments.

238. To land Unity safely, pilots must aim for an imaginary inverted vertical landing cone. Unity "enters" the cone when dropped by Eve and must stay within the cone during the entire flight. The cone gradually narrows until Unity reaches the landing strip.

239. Deviating from the cone is dangerous because the vehicle may not have enough energy to make it back to the landing strip. Unity would then have to land somewhere else. A crash landing would imperil all aboard.

240. As Schmidle explained in a September 1, 2021 *New Yorker* article about the July 11 flight, a yellow cockpit warning light indicates to the pilots that Unity is about to leave the cone; a red warning light indicates that it has left the cone.

241. Virgin Galactic's world-class test pilots, who take on extraordinary risks every flight, are petrified of leaving the cone.

242. As Schmidle continued in the September 1 *New Yorker* article:

I once sat in on a meeting, in 2015, during which the pilots [who would later pilot] the July 11th [2021] mission—Dave Mackay, a former Virgin Atlantic pilot and veteran of the U.K.'s Royal Air Force, and Mike Masucci, a retired Air Force pilot—and others discussed procedures for responding to an entry glide-cone warning. C. J. Sturckow, a former marine and NASA astronaut, said that a yellow light should “scare the s\*\*\* out of you,” because “when it turns red it's gonna be too late”; Masucci was less concerned about the yellow light but said, “Red should scare the cr\*p out of you.”

243. According to Schmidle, on the July 11 flight, when Unity had reached 20 miles (about 30 miles short of its apogee), the yellow light turned on in Unity's cockpit indicating that it was straying from the glide cone. A few seconds before the end of Unity's burn, it was joined by the red one, indicating that it *had* strayed.

244. The pilots were eventually able to bring Unity back into its glide cone. But Virgin Galactic acknowledged in response to questions from Schmidle that Unity strayed outside of its FAA airspace for 1 minute 41 seconds, or more than 10% of the journey. Delta Airlines flight DAL637 was then in adjacent airspace.

245. On July 11, 2021, at 6:00 PM UTC, Virgin Galactic held a preliminary post-flight debriefing with the FAA. Virgin Galactic did not disclose that it had strayed from its airspace.

246. On July 21, 2021, on a weekly call, the FAA told Virgin Galactic to provide the FAA with a “summary report” “for the ‘ENTRY GLIDE CONE’ CAS messages that were displayed during final seconds of the boost phase” of Branson's flight.

247. On July 23, 2021, the Albuquerque Air Control Center texted the FAA that Virgin Galactic's spaceship had left protected airspace during the Branson flight and that it had filed a Mandatory Occurrence Report, triggering FAA involvement.

248. On a July 28, 2021 weekly call with the FAA, Virgin Galactic was told to “[e]xpect[] a letter from the FAA noting the excursion.”

249. On August 3, 2021, Virgin Galactic briefed the FAA on the incident. David Mackay, pilot in command of the July 11 flight, gave a presentation. The presentation's opening slide stated: “What happened[.] Why it happened[.] What we are doing to ensure it doesn't happen again[.]” In the presentation, Mackay admitted that the flight had strayed from its FAA airspace and that the FAA had not been told as much. He stated that he and the co-pilot had not been able to tell the FAA of straying because they were focused on “conserving energy levels for safe glide recovery to Spaceport America.” He also stated that Virgin Galactic was investigating the root cause of the straying.

250. On August 11, 2021, the FAA concluded its investigation with an email to Virgin Galactic's management which provided, among other things, that the July 11 2021 flight was a “launch incident” “mishap”<sup>8</sup> “as a failure of VG's safety organization, design, or operations to properly communicate real-time vehicle status during flight operations essential to during flight

---

<sup>8</sup> “Mishap”, a term of art, describes a serious incident that did not result in an accident. It is defined as “a launch or reentry accident, launch or reentry incident, launch site accident, failure to complete a launch or reentry as planned, or an unplanned event or series of events resulting in a fatality or serious injury (as defined in 49 CFR 830.2), or resulting in greater than \$25,000 worth of damage to a payload, a launch or reentry vehicle, a launch or reentry support facility or government property located on the launch or reentry site.” 14 C.F.R. § 401.5. A reentry incident is defined as “any unplanned event occurring during the reentry of a reentry vehicle, other than a reentry accident, involving a malfunction of a reentry safety-critical system or failure of the licensee's or permittee's safety organization, procedures, or operations.” 14 C.F.R. § 401.5.

operations essential to ensuring public safety.” The FAA required that Virgin Galactic “provide a final report and implement corrective actions prior to conducting further FAA-licensed launches.”

251. Virgin Galactic withheld the fact that it had strayed from its airspace from the public and, initially, even from the FAA.

252. Thus, Defendants Virgin Galactic and Branson collectively sold \$800 million of shares after the July 2021 flight while in possession of material nonpublic information.

253. At 1:35 PM on September 2, 2021, the FAA announced that it was grounding Unity. Within minutes of the FAA’s announcement, Virgin Galactic’s stock price fell from about \$28 to about \$25, ending the day at \$25.99. Virgin Galactic’s stock price continued to fall by \$1.71 on September 3, 2021, closing at \$24.28.

254. The FAA grounded Unity because it had dangerously strayed from its airspace during the flight that took Defendant Branson to space.

255. At the time, Virgin Galactic falsely told investors the FAA’s investigation began on August 11, or after Branson’s stock sales had begun.<sup>9</sup> Yet, as set out in a September 8, 2021 article, the FAA told *The Washington Post* its investigation began on July 23, before Branson started selling his stock. In a September 16 report, Bank of America analysts castigated Virgin Galactic for its conduct. The analysts reported that “[s]elective disclosure can be a culture red flag.”

256. The analysts called Virgin Galactic’s decision “to have an event that, per FAA regulations, is considered a mishap and then claim that the mission was a full success” is “[p]oint blank [] unacceptable.”

---

<sup>9</sup> <https://www.virgingalactic.com/articles/virgin-galactic-cleared-to-fly-following-conclusion-of-faa-inquiry/>

257. The analysts even suggested that Virgin Galactic's assurances that the incident was not dangerous may not be true:

[Virgin Galactic] insists the deviation was a result of high winds (as opposed to operator error or technical failure) and that at no time were its passengers/crew in danger. We wonder then, why not disclose in a clear and timely fashion?

258. Stucky also said Virgin Galactic's explanation was misleading. As he tweeted: "The most misleading statement today was @virgingalactic's. The facts are the pilots failed to trim to achieve the proper pitch rate, the winds were well within limit, they did nothing of substance to address the trajectory error, & entered Class A airspace without authorization." He added "but if that's their definition of proper procedures and safety being paramount, well there you have it."

259. Defendants' representations that Branson's July 11, 2021 flight was "successful," "perfect," and "flawless" were misleading because they omitted to disclose *Unity's* dangerous departure from its landing cone during the flight, concealing the risk of regulatory intervention, which materialized in the FAA grounding *Unity*.

*f. October 14, 2021*

260. Throughout 2021, Defendants discussed at Board meetings that *Unity* and *Eve* needed extensive structural modifications. For example, at a March 26, 2021 meeting, the Board was told that *Unity* needed at least six months of "Structural Modifications" before commercial flights and that *Eve* needed, among other things, "engine upgrades, pylon replacement and structural modifications."

261. On the Q4 2020 earnings call, Defendants had announced that Virgin Galactic planned to undertake some "upgrades" and "enhancements" to *Eve* before commercialization. On the Q1 2021 earnings call, Defendants announced that these "enhancements" would take place immediately after the Italian Air Force flight.

262. On the Q1 2021 and Q2 2021 earnings calls, Defendants reassured investors that the improvements would not cause significant delays. On the Q1 2021 call, Defendants asserted that the improvements would take four months. Defendants also allayed an analyst's concern that because Eve was 13 years old, it was unpredictable and showed signs of wear by asserting that Eve was more durable than a commercial airliner and had far less flight time.

263. On the Q2 2021 earnings call, Defendants declared that because the Branson flight was so successful, they would abandon the third flight and go straight to the Italian Air Force flight. On that call, Defendants asserted that the enhancement period would take eight months. Yet, with Branson eager to sell hundreds of millions of dollars of shares, Defendants reassured investors that the enhancement period's length was predictable because “*[f]unctionally, this is kind of a life extension program on Eve, and so that's I think very well known in the aerospace industry of how to go about that.*”

264. On October 14, 2021, Defendants announced that they had rescheduled the Italian Air Force flight to take place after the enhancement period because a “recent laboratory-based test[] flagged a possible reduction in the strength margins of certain materials used to modify specific joints, and this requires further physical inspection.”

265. Analysts were surprised:

- a. In an October 14 report, Canaccord Genuity analysts noted that “The announcement comes as a surprise, considering that the FAA had given Virgin the go-ahead to fly its chartered spaceflight for the Italian Air Force in mid-October, which would have otherwise been imminent.”
- b. In an October 17 report titled *Another long pushout pushes downgrade to sell*, UBS analysts downgraded Virgin Galactic's stock price target from \$26 to \$15 and made

its recommendation to Sell.

- c. In an October 19 report, Morgan Stanley analysts reduced their price target from \$25 to \$17 and noted that “Our biggest takeaway from the delay of [the Italian Air Force flight] and the long enhancement period for Eve is that commercialization and high volume operations could take much longer than the company initially anticipated.”

266. On October 15, 2021, the price of Virgin Galactic shares fell from its previous close of \$24.06 to close at \$20.01, down \$4.05 (16.9%).

267. The cancellation of the Italian Air Force flight was a materialization of the risk that Eve was far less rugged than Defendants asserted, and that Defendants knew far less about its structure than their statements implied.

*g. January 13, 2022*

268. On January 13, 2022, before trading, the Company announced it would offer \$425 million aggregate principal amount of convertible senior notes in a private offering. Virgin Galactic stated further that:

**The Company intends to use the net proceeds from the offering *to fund working capital, general and administrative matters and capital expenditures to accelerate the development of its spacecraft fleet in order to facilitate high-volume commercial service.***

269. On January 13, Virgin Galactic’s stock price fell from its previous close of \$12.37 to close at \$10.02, down \$2.34 (18.9%).

270. That Defendants needed to “accelerate the development of its spacecraft fleet in order to facilitate high-volume commercial service” was directly related to Defendants’ concealment of issues alleged herein that severely impacted the facilitation of high-volume

commercial service and was the materialization of the risk that Unity and Eve needed major repairs and neither was capable of regular flights as previously represented.

*h. August 4, 2022*

271. The enhancement to Eve did not proceed as Defendants represented. On a call to discuss Q1 2022 earnings, Defendants pushed back commercial flights to Q4 2022. Then, on an August 4, 2022 call to discuss Q2 2022 earnings, they pushed back commercial flights to the first half of 2023.

272. On the Q2 2022 call, Defendant Colglazier admitted when asked about the cause of the delay that supply chain issues, which he had blamed on the Q1 2022 call, were “not really the driver.” Instead, Colglazier blamed the fact that “the ships, as built, are different enough from the drawings that we had, that we need to go back and conform those drawings to the as-builts.”

273. In an August 5, 2022 report, a Canaccord Genuity analyst explained that in additional conversations, Virgin Galactic “indicated that the engineering team noticed slightly different angle measurements on the actual pylon to which the spaceship is attached than what was reflected on the original engineering drawings, which required some changes to upgraded components considering that the wing on Eve is very thin.” The analyst also reduced his price target from \$8 to \$7.

274. On August 5, 2022, the price of Virgin Galactic’s shares fell from their previous close of \$8.19 to close at \$6.76, down \$1.43 (17.5%), damaging investors. The corrective disclosure was the materialization of a risk Defendants had concealed from investors that Virgin Galactic did not have accurate engineering drawings of Unity or Eve.

## VII. DEFENDANTS' FALSE STATEMENTS

### A. Defendants' July 9, 2019 Announcement Of The Reverse Merger

275. On July 9, 2019, Defendants announced the Reverse Merger transaction. A Press Release attributed to Virgin Galactic and SCH and quoting Branson, Whitesides, and Palihapitya, stated:

VG believes it has now reached an inflection point in its development as it progresses towards launching commercial operations. *In particular, by demonstrating the repeatability of the full flight profile through the completion of two crewed spaceflights, VG believes it has overcome a substantial number of the technical hurdles required to make the company a viable and profitable commercial service.*

276. These statements were false and misleading because they implied that Virgin Galactic had overcome many of the hurdles necessary to commercial service and gave reasonable investors the misleading impression that only minor technical hurdles remained, when, in truth, Unity was grounded after the February 2019 flight because its horizontal stabilizers had suffered critical damaged and needed to be replaced.

277. The July 9, 2019 Press Release also provided that:

VSS Unity, VG's spaceship, was the first and remains the only vehicle *built for regular commercial service* to have put humans into space.

278. The statement that Unity was "*built for regular commercial service*" was false and misleading because: (a) Unity and Eve were built as prototypes that Defendants always intended would only rarely fly paying passengers; (b) Unity and Eve cracked after every flight, necessitating repairs that would prevent them from ever flying regularly; (c) Defendants did not have engineering drawings of Unity or Eve so they could not modify them to fly regularly.

279. Also on July 9, 2019, in a letter announcing the Reverse Merger, Defendant Branson stated:

Opening Virgin Galactic to further external investment has been on the cards for a while. *Great progress in our test flight program means that the remaining hurdles, before our*

*beautiful spaceship starts a full commercial service, are steadily being cleared.* Having sadly had to pull away from an investment by Saudi Arabia after the murder of journalist Jamal Khashoggi, and then *having demonstrated the repeatability of our full flight profile with two crewed spaceflights*, we had an opportunity to rethink our investment plans.

280. This statement was false and misleading because it affirmatively misrepresented that the February 2019 flight had “demonstrate[ed] [Unity’s] full flight profile” and “clear[ed]” an important milestone when, in fact, the flight nearly resulted in disaster and ended in the undisclosed grounding of Unity and the need to replace Unity’s critical horizontal stabilizers. The assertion that “[g]reat progress in our test flight program means that the remaining hurdles [] are steadily being cleared” was materially misleading for the same reasons.

281. On July 9, 2019, Defendants Branson and Palihapitiya appeared on CNBC to promote the Reverse Merger and Virgin Galactic going public. During the interview, Branson and Palihapitiya were asked specifically about public investors’ concerns regarding risks and regulatory requirements. In response, they misleadingly sought to assure investors about safety and regulatory status as they drummed up excitement for purchasing Virgin Galactic stock:

Q: You will have public investors with this business. I mean, obviously, you’re gonna have to assure them that, you know, the risks are under control. I mean, the regulatory framework and all that. How do you go about that?

**DEFENDANT BRANSON:** I think one thing is the part that Chamath is willing to put 100 million of his own money in, and he also independently bought a ticket to space, and he spent a lot of time doing due diligence on the company.

**DEFENDANT PALIHAPITIYA:** Yeah, in fact, I mean, we went through all of those checklists that you just mentioned, so *from a safety perspective, how do we know that this thing is going to be an incredibly safe experience?* It was at the end of that process that I bought my ticket because I just became convinced that this is actually as safe or safer, frankly, than flying in a traditional airplane. They’re licensed by the FAA. *They have all the regulatory elements in place to start commercial operations. That was a huge part of our justification. So you’re exactly right that all of these things are critical to making sure that public investors have the full picture.* I think the thing is that once we’re able to sort of file the statements, et cetera, and see the presentations and all the work that we’ve done, you’ll see that these guys have done an incredible amount of work and that they really are building something exceptionally unique and special; and that’s just rare. These things aren’t that common, and people like Richard aren’t that common.

And so to be able to partner with them for folks like us is just, it's a special opportunity.

282. Palihapitiya's statements that Virgin Galactic was "licensed by the FAA" and that "[t]hey have all the regulatory elements in place to start commercial operations" were materially false and misleading. The Company did *not* have "all the regulatory elements in place to start commercial operations." Rather, it was not allowed to fly paying passengers until it met the FAA's requirements that it validate and verify 29 points, which required additional test flights. Further, contrary to Palihapitiya's false assurances in this interview, public investors did not have anywhere close to "the full picture" of Virgin Galactic's safety and regulatory risks where Defendants knew but did not disclose that Virgin Galactic's safety testing of Unity revealed significant undisclosed problems in the months preceding the Class Period, including that Virgin Galactic had grounded Unity after the near-disastrous February 2019 test flight to address crucial safety issues following the flight in which its horizontal stabilizers "suffered critical damage" and needed complete replacement.

#### **B. The Registration Statement**

283. On August 7, 2019, Defendants caused to be filed on Form S-4 the Registration Statement for the Reverse Merger, the prospectus for which was filed on October 10, 2019 (collectively, the "Registration Statement"). Among other things, the Registration Statement provided that:

**Attractive Business Model.** The VG Companies *have several capabilities* that will allow them to scale rapidly to meet customer demand – among these are the design and implementation of reusable vehicles. *For example, a single spaceship is designed to be reused for hundreds of cycles, with primarily only its rocket motor fuel cartridge and oxidizer being changed in between flights. These design features meaningfully reduce the operational cost of each spaceflight over time and allows for short turnaround times between flights.* Over time, the VG Companies expect to have the ability to leverage their suite of proprietary technologies and reusable design to lower costs and allow lower ticket prices, while

preserving profitability and meeting the demand for human spaceflight in a market where most other alternatives are extremely expensive.

\* \* \* \* \*

**Strong Competitive Position.** The VG Companies’ differentiated technology and capabilities, its horizontal take-off and landing design, experienced management team, iconic brand, vertically-integrated design and manufacturing capabilities and extensive customer base separate them from the competition. VSS Unity, the VG Companies’ spaceship, was the first, and as of July 2019 remains the only, *vehicle built for recurring commercial spaceflight service to have put humans into space.*

\* \* \* \* \*

***Our carrier aircraft, WhiteKnightTwo.*** WhiteKnightTwo is a twin-fuselage, custom-built aircraft designed to carry our spaceship, SpaceShipTwo, up to an altitude of approximately 45,000 feet, where the spaceship is released for its flight into space. ***Our carrier aircraft is designed to launch thousands of SpaceShipTwo flights over its lifetime.*** This reusable launch platform design provides a flight experience and economics similar to commercial airplanes, and may offer a considerable economic advantage over other potential launch alternatives. Additionally, ***our carrier aircraft has a rapid turnaround time, enabling it to provide frequent spaceflight launch services for multiple spaceships.***<sup>10</sup>

\* \* \* \* \*

We are now in the ***final phases of readying our commercial spaceflight program [] completing the final work on VSS Unity*** for commercial service, including the installation of the cabin interior. The interior furnishings and fixtures are also being installed at Spaceport America, along with finalizing everything needed to prepare our first customers for flight. We expect to conclude the final portion of the flight

---

<sup>10</sup> Defendants repeated these statements about Eve in other Virgin Galactic SEC filings during the Class Period, including: 2019 Form 10-K filed on February 28, 2020 at p. 6 (“Our carrier aircraft is designed to launch thousands of SpaceShipTwo flights over its lifetime .... Our carrier aircraft has a rapid turnaround time, enabling it to provide frequent spaceflight launch services for multiple spaceships.”); 2020 Form 10-K filed on March 1, 2021 at pp. 5-6 (“Our carrier aircraft is designed to launch thousands of spaceship flights over its lifetime. This reusable launch platform design provides a flight experience and economics similar to commercial airplanes and may offer a considerable economic advantage over other potential launch alternatives. Additionally, our carrier aircraft is designed to have a rapid turnaround time to enable it to provide frequent spaceflight launch services for multiple spaceships.”); 2021 Form 10-K filed on February 28, 2022 at p. 5 (“Our carrier aircraft is designed to launch thousands of spaceship flights over its lifetime. This reusable launch platform design provides a flight experience and economics similar to commercial airplanes and may offer a considerable economic advantage over other potential launch alternatives. Additionally, our carrier aircraft is designed to have a rapid turnaround time to enable it to provide frequent spaceflight launch services for multiple spaceships.”)

test program from Spaceport America and expect successful completion of those tests to lead to *our first commercial flight in 2020*.<sup>11</sup>

284. These statements were materially false or misleading because: (a) Virgin did not then “have” the “capabilities” of “design and implementation of reusable vehicles” that would enable the Company to “scale rapidly to meet customer demand”; (b) Unity was not “built for recurring commercial spaceflight” and Eve was not “designed to launch thousands of SpaceShopTwo [Unity] flights” over its lifetime; rather, both vehicles were mere prototypes neither designed for, nor capable of, ongoing and recurring commercial use at anything more than a token scale; (c) Eve did not have “a rapid turnaround time” because, among other things, it constantly developed cracks after flights, thus requiring extensive checks and frequent repairs, taking an average of one month between flights; (d) Defendants did not know how Unity and Eve were “designed” because Virgin Galactic did not have accurate engineering drawings; and (e) Virgin Galactic was neither “in the final phases of readying our commercial spaceflight program” nor “completing the final work on VSS Unity” (*i.e.*, focused on details such as cabin interiors of Unity), but instead was focused on developing and/or installing new, untested parts to replace critical parts that had either been destroyed or needed substantial modification, including, for example, Unity’s horizontal stabilizers and its flight control systems.

### **C. September 2019 Prospectuses and Presentations**

285. On September 5, 2019, Defendants filed as a prospectus pursuant to Rule 425 a series of Analyst Day Presentation slides regarding Virgin Galactic. On September 26, 2019, Defendants filed as a prospectus pursuant to Rule 425 a series of Investor Presentation slides

---

<sup>11</sup> Defendants again claimed to be in the “final phases of readying our commercial spaceflight program” in the 2020 Form 10-K, filed on March 1, 2021. And they still claimed to be “in the final phases of developing our commercial spaceflight program” in the 2021 Form 10-K, filed on February 28, 2022.

regarding Virgin Galactic. Both presentations included a slide titled “VSS Unity” claiming Unity was “The world’s first private, crewed spaceship *designed for commercial service* to take humans to space”:<sup>12</sup>

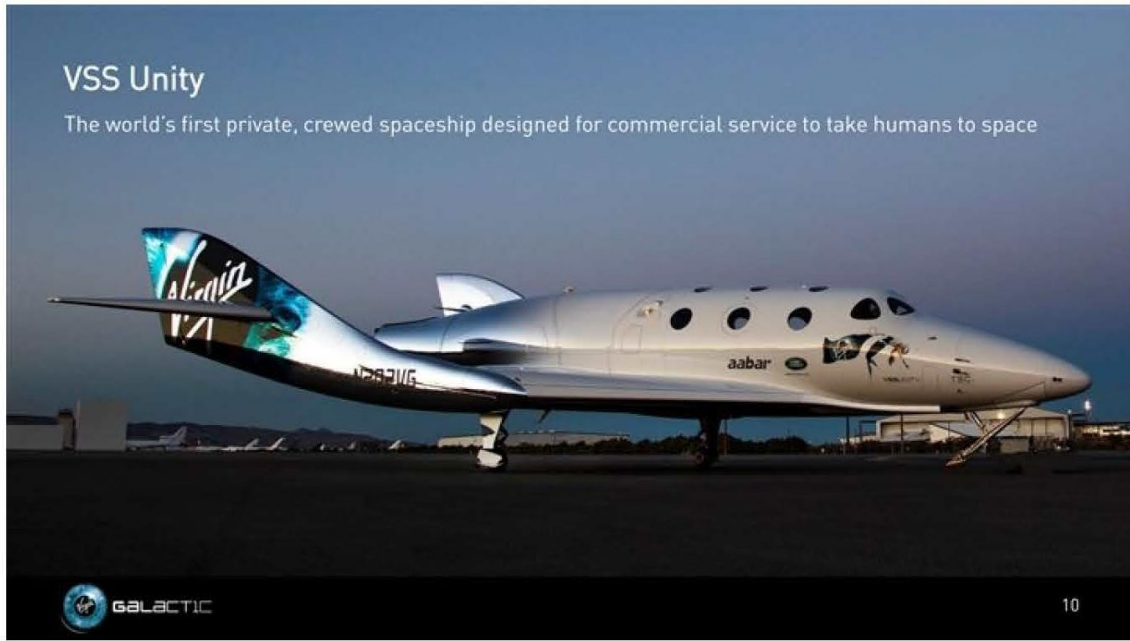

286. The claim that Unity was “designed for commercial service to take humans to space” was materially false and misleading because: (a) Unity and Eve were built as prototypes that Defendants always intended would only rarely fly paying passengers; (b) Unity and Eve cracked after every flight, necessitating repairs that would prevent them from ever flying regularly; (c) Defendants did not have engineering drawings of Unity or Eve so they could not modify them to fly regularly.

287. Both presentations also included a slide purporting to represent the development status of Unity and Eve, reflecting Eve as fully completed and operational and Unity as fully designed and assembled and nearly complete on flight testing, with “Year of Build Completion”

---

<sup>12</sup> This slide is taken from the September 5, 2019 presentation. The identical slide is included at slide 8 of the September 26, 2019 presentation.

in 2019 (*i.e.*, within the next three months):<sup>13</sup>

### Fleet Build Progress and Expected Expansion Schedule

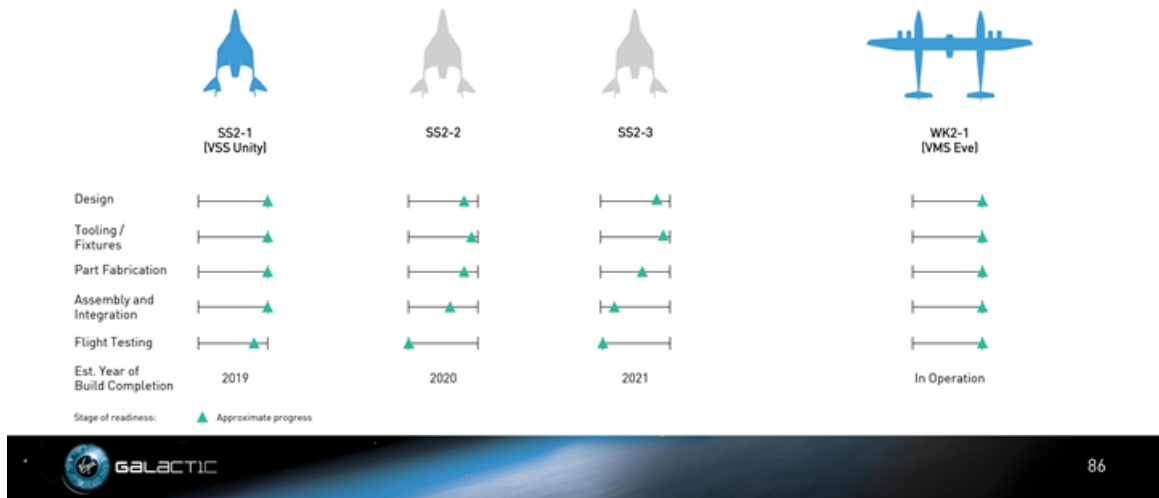

288. The statements made in that slide were false because: (a) Virgin Galactic had not completed Unity’s Design, Tooling/Fixtures, Part Fabrication, and Assembly and Integration, in that (i) Unity had no horizontal stabilizers, (ii) Virgin Galactic was in the process of developing and installing a digital control system, and (iii) Defendants discussed internally that they would have to replace other parts of Unity to address its poor damage tolerance; (b) Virgin Galactic had not completed Eve’s Design, Tooling/Fixtures, Part Fabrication, Assembly and Integration, or Flight Testing, in that Eve’s pylon was unsuitable for repeated commercial flights, among other things; (c) Eve was not “in operation” because without significant modifications, replacements, and repairs, it was unsuitable for commercial operations; and (d) Unity and Eve’s Designs were not complete because Virgin Galactic did not have accurate engineering drawings of either vehicle and understood it would have to replace significant portions of each vehicle. Underscoring the

<sup>13</sup> This slide is taken from the September 5, 2019 presentation. The identical slide is included at slide 36 of the September 26, 2019 presentation. The relevant portions are excerpted in ¶4.

falsity of the “Build Progress” claims relating to Unity, in particular, Defendants concealed the serious structural failure of Unity during its February 2019 test flight, including that the horizontal stabilizers had “popped like a bag of chips” and that Virgin Galactic had grounded Unity following that flight because the horizontal stabilizers needed complete replacement. And demonstrating the falsity of the “Build Progress” claims relating to Eve, the Virgin Galactic board presentation materials from November and December 2019 show that Eve was not fully complete and operational for commercial use; rather, Eve had major structural issues with its pylon—the critical component that attached Unity to Eve and from which Unity launched—which, prior to the November/December 2019 Board materials, had “been the subject of on-going structural analysis for long-term commercial service.” Further, the Board was informed that “putting on a new pylon” “could be a key critical path to regular commercial service.”

289. Both presentations also included slides that provided:<sup>14</sup>

### Shorter Launch Preparation Times Compared to Traditional Vehicles

**Target WK2 and SS2 Operational Parameters**



- Anticipated monthly flight rate: **15 flights** per vehicle (at scale)
- Supported by **2 days of scheduled maintenance** per week
- **5-day scheduled maintenance** period per month, coinciding with SS2 downtime



- Anticipated monthly flight rate: **5 flights** per vehicle (at scale)
- Supported by **5-day operational turnaround** after each flight
- **7-day scheduled maintenance** period per 5-flight cycle; scheduled annual downtime of 1 month

Pre-Flight Activity	Duration
WK2 Fueling	< 30 minutes
Rocket Motor CTN Physical Install	4 hours
SS2 Jack and Mate to WK2	< 1 hour
Pressurant Tank Load / Boost	1 hour
Nitrous Load	2.5 hours



<sup>14</sup> These slides are taken from the September 5, 2019 presentation. The identical slides appear at slides 39 and 41 of the September 26, 2019 presentation, respectively.

## Key Assumptions

Start of Commercial Operations	<ul style="list-style-type: none"><li>Financial projections assume <b>June 2020 commencement of commercial operations</b>, starting with one vehicle in service</li></ul>
Flight Rates	<ul style="list-style-type: none"><li>Modest flight rates at commercial start, scaling up to an <b>ultimate anticipated flight rate of 5 per month</b> in 2022 and thereafter</li></ul>
Vehicle Build and Operational Stats	<ul style="list-style-type: none"><li>Second and third SS2 vehicles (SS2-2, SS2-3) are currently under construction and are expected to be complete by the end of 2020 and 2021, respectively</li><li>Build time of <b>approximately 24 months</b> for SS2-4 through SS2-5</li><li>While vehicles have capacity for 6 passengers, early projection years assume lower passengers per flight<ul style="list-style-type: none"><li>SS2-1 (VSS Unity) passengers per flight starts at 4, increasing to 5 in 2021 onwards</li><li>SS2-2 and SS2-3 passengers per flight start at 5, increasing to 6 in 2021 onwards</li><li>Run-rate of <b>6 passengers per flight</b> throughout life of SS2-4 and SS2-5 vehicles</li></ul></li></ul>



290. The statements in the slides above regarding Eve and Unity’s flight rate and the “June 2020 commencement of commercial operations” and described the performance of “vehicles” without distinguishing between Unity and new spaceships were false or misleading because Defendants knew that: (a) Unity was grounded and in need of complete replacement of its horizontal stabilizers; (b) Unity still had extensive testing to conduct; (c) Unity and Eve were prototypes that would require extensive modifications before flying *any* commercial passengers; (d) Unity and Eve were prototypes and so would never be able to fly as frequently as new vehicles rolling off the factory floor, if Defendants were able to make them suitable for commercial service at all; and, therefore (e) Defendants knew that it was impossible for Unity and Eve to begin commercial service by June 2020 or to enter into full commercial service.

291. In addition to claiming the Company would launch commercial spaceflight by June 2020, both presentations represented that with two vehicles operating in 2020 (*i.e.*, Eve and Unity),

the Company would complete 16 total flights in 2020:<sup>15</sup>

### Key Assumed Operational Metrics and Revenue

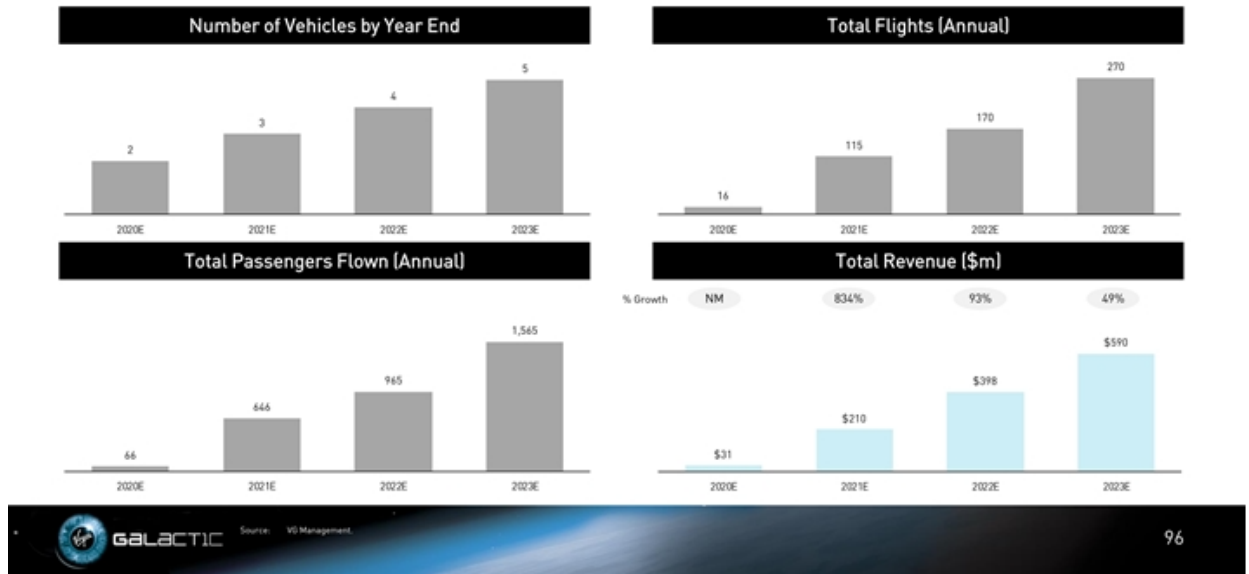

292. The statements in the slides above regarding Eve and Unity’s 2020 flight rate were false or misleading because Defendants knew that: (a) Unity was grounded and in need of complete replacement of its horizontal stabilizers; (b) Unity still had extensive testing to conduct; (c) Unity and Eve were prototypes that would require extensive modifications before flying *any* commercial passengers; (d) Unity and Eve were prototypes and so would never be able to fly as frequently as new vehicles rolling off the factory floor, if Defendants were able to make suitable for commercial service at all; (e) both Unity and Eve developed cracks after flights, particularly in parts of the vehicles that had previously been bonded with resin, requiring significant maintenance and repair time between flights, usually a month for Eve; and, therefore (f) Defendants knew that it was impossible for Unity and Eve to begin commercial service by June 2020, let alone complete 16 commercial flights in the six months between June and December 2020.

<sup>15</sup> This slide is taken from the September 5, 2019 presentation. The identical slide appears at slide 43 of the September 26, 2019 presentation.

293. Defendants further included a slide titled Practically Driven Principles and Approaches, which stated that Virgin Galactic did “digital definition and configuration management via Oracle”:

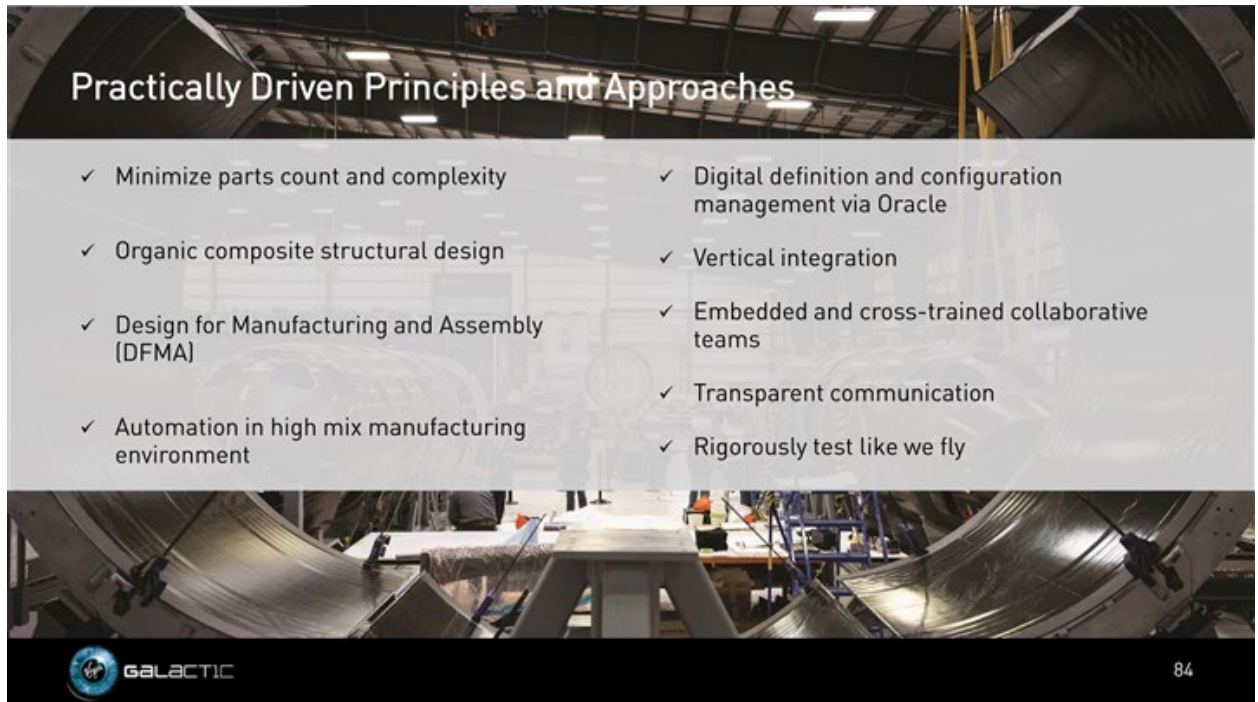

294. Defendants’ statement that Virgin Galactic maintained “digital definition and configuration management via Oracle” was misleading because Virgin Galactic employed three different databases and methods for configuration management—Oracle, Agile, and Ultramain—which were not linked such that making a change in one database would effect changes in the other two. The information contained in these databases was mutually inconsistent, raising doubts about the accuracy of any given piece of information in the databases, creating logistical nightmares, and making it difficult to store information about Virgin Galactic’s “as built” vehicles. These mutually inconsistent databases were a cause of, though not the only cause, of Virgin Galactic’s inability to understand its vehicles’ “as built” configuration. The statement that Virgin Galactic employed just one database was materially misleading because it gave investors the impression that Virgin

Galactic's configuration management was well organized and well understood while concealing that Virgin Galactic's design, repair, and improvement operations were in disarray, leading to delays and potential safety problems.

**D. Branson's October 28, 2019 Bloomberg Interview**

295. On October 28, 2019, on Bloomberg Video, Defendant Branson stated as follows:

**Q:** And, Richard, you've been in this race for a long time. Obviously, now, competing against some other big names—Jeff Bezos and Elon Musk among them. What's the first-mover advantage here?

**DEFENDANT BRANSON:** Well, I think, we have the advantage of having already put people into space and we've made five new astronauts; there haven't any others made on American soil since 2009. ***And, so, we have a tested and tried system that is performing well.*** And we're building – using the money that we've raised today, we can build a lot more spaceships and motherships, and a lot more rockets, and we're able to build the number of people that are able to go into space.

296. Branson's statements were false because (a) on the February flight, the latest as of Branson's statement, Unity's horizontal stabilizers had popped mid-flight, endangering the lives of everyone on the spaceship and requiring lengthy repairs; (b) all of Unity's flights had taken place using manual controls that left Unity shaking uncontrollably between Mach 1.5 and 2 and which Defendants acknowledged needed to be replaced; (c) Unity's flight tests were one near disaster after another; and (d) Unity and Eve were prototypes which needed weeks to months of downtime after every flight and would never be able to make more than token commercial flights.

**E. Defendants' December 13, 2019 Press Release**

297. On December 13, 2019, Defendants published a press release titled *Reflecting on a Remarkable Year* on Virgin Galactic's website. In the press release, Defendants stated:

Virgin Galactic reaches space for the second time

***Ten weeks after our first flight to space, we did it again, travelling higher and faster than ever before and, for the first time, with a third crew member on board. This flight*** saw two more of our pilots, Dave Mackay and Mike 'Sooch' Masucci, become commercial astronauts, with Chief Pilot Mackay entering the

record books as the first Scot in space. Our Chief Astronaut Instructor, Beth Moses, flew as the third crew member to carry out a live evaluation of cabin dynamics—floating freely in zero gravity. She became the first woman to fly on board a commercial spaceship and had the coveted honor of being awarded the title of Commercial Astronaut 007.

298. The words “This flight” were a link to a February 22, 2019 press release Defendants published and placed on Virgin Galactic’s website titled *Virgin Galactic Makes Space for Second Time in Ten Weeks with Three on Board, Reaching Higher Altitudes and Faster Speeds, as Flight Test Program Continues*, which provided:

The crew enjoyed extraordinary views of Earth from the black skies of space and, during several minutes of weightlessness while the pilots “feathered” the spaceship in preparation for a Mach 2.7 re-entry, Beth floated free to complete a number of cabin evaluation test points. ***The human validation of data previously collected via sensors, and the live testing of other physical elements of the cabin interior, are fundamental to the provision of a safe but enjoyable customer experience.***

\* \* \* \* \*

Addressing colleagues and guests Dave said: “Beth, Sooch and I just enjoyed a pretty amazing flight which was beyond anything any of us has ever experienced. It was thrilling yet smooth and nicely controlled throughout with a view at the top, of the Earth from space, which exceeded all our expectations. ***I am incredibly proud of my crew and of the amazing teams at Virgin Galactic and The Spaceship Company for providing a vehicle and an operation which means we can fly confidently and safely.*** For the three of us today this was the fulfillment of lifelong ambitions, but paradoxically is also just the beginning of an adventure which we can’t wait to share with thousands of others.”

Sir Richard Branson said: “***Flying the same vehicle safely to space and back twice in a little over two months, while at the same time expanding the flight envelope, is testament to the unique capability we have built up within the Virgin Galactic and The Spaceship Company organizations.*** I am immensely proud of everyone involved. Having Beth fly in the cabin today, starting to ensure that our customer journey is as flawless as the spaceship itself, brings a huge sense of anticipation and excitement to all of us here who are looking forward to experiencing space for ourselves. The next few months promise to be the most thrilling yet.”

299. These statements were false and misleading because: (a) they were made shortly after the February 2019 flight which left *Unity* critically damaged and was a near-disaster; (b) the

February 2019 test flight did not suffer from a minor operational problem but a serious structural failure of the spacecraft; (c) on that flight, the horizontal stabilizer “popped like a bag of chips,” but avoided disaster because it popped in the “right spot.”; and, therefore because a reasonable investor would not conclude that this level occurred from the description of the flight as “safe,” these statements were materially misleading.

**F. Defendants’ May 5, 2020 Earnings Call (Q1 2020)**

300. During Virgin Galactic’s Q1 2020 earnings call on May 5, 2020, in response to a question about “the key gating items” to Virgin Galactic’s first commercialized flight and whether the Company was “still on-schedule” for its first commercial launch in the summer of 2020, Defendant Whitesides stated:

**Q:** What are the key gating items among those three that you need to get through to get to this first commercial flight? And are you still on-schedule for mid-summer? It sounded before like this—the schedule’s in flux a little bit as you get everything as perfect as you needed.

**DEFENDANT WHITESIDES:** Yeah. Well, as you know, our number one priority is to fly safely, and not just Sir Richard, but anybody we fly whether it’s the pilots that we fly or employees that we might fly in the late test pilot program, that’s our number one priority. What we’re affirming today as you know that our number one priority is to fly Richard Branson into space on a commercial flight in 2020. That’s what our entire organization is really that they know that that’s the top priority.

I don’t mind breaking out a little bit more detail in terms of these three areas. I did talk about it a little bit during those remarks in terms of the finishing the test flight program, we’re going to be needing to do some glide flights and some rocket-powered flights obviously in terms of the end-to-end customer experience. It’s not just the in-flight experience, it’s also the on-the-ground experience. It’s even the—before you get to Spaceport experience, we really are working really hard on all of those spaces, but obviously a lot of—there’s going to be a lot of focus on the cabin experience in the seats and the suits and the interaction between all of those things.

And then the third thing is *readying the vehicles for long-term, high-rate service*, I talked a little bit about that in my comments. Still, we want—we really want to make that a big focus. Because we know, ultimately, the amount of revenue that we generate in 2020 is really not the thing that’s going to make this company a great success. What’s going to make it a great success *is having a vehicle that we can*

*turn around relatively rapidly and do that on a consistent basis and then build a fleet of them*, so that we can add more capacity into the market.

301. These statements were misleading because Unity and Eve were prototypes that would never be “ready[.]...for long-term, high-rate service....” Moreover, Whitesides’ focus on internal cabin details and customers’ “on-the-ground experience”, in response to the question “are you still on-schedule for [a] mid-summer” commercial launch—while omitting that Unity was grounded pending replacement of its critical horizontal stabilizers—was materially misleading. Further, Whitesides’s claim that Virgin Galactic aimed to build “a vehicle that we can turn around relatively rapidly”—Unity—“and do that on a consistent basis and then build a fleet of them”—the other SS2 model spaceships—gave the misleading impression that Unity would fly as frequently as the other SS2 model spaceships.

#### **G. Defendants’ June 25, 2020 Press Release**

302. On June 25, 2020, Virgin Galactic published a press release announcing its second glide flight from Spaceport America. The press release quoted Defendant Whitesides as saying:

“I am thrilled with the team’s hard work to complete today’s test flight successfully. It was an important test that, pending data review, means we can now start preparing the vehicles for powered flight. Our focus for this year remains unchanged on *ensuring the vehicles* and our operations *are prepared for long-term, regular commercial spaceflight service.*”

303. The statement that Virgin Galactic was focused on ensuring “the vehicles”—*i.e.*, Eve and Unity, “are prepared for long-term, regular commercial spaceflight service” was materially false and misleading because those vehicles were mere prototypes that were not designed or intended to be used in “long-term, *regular* commercial spaceflight service” and Defendants knew that they could not withstand such long-term, regular commercial service.

#### **H. Defendants’ November 2020 Press Release**

304. On November 5, 2020, Virgin Galactic issued a press release providing, in relevant

part:

***Implemented upgraded flight control system and upgraded horizontal stabilizers on VSS Unity to increase performance during the boost phase of the flight profile.***

305. These statements were false and misleading because: (a) they described the new stabilizers as “upgraded” or similar, which conceals from investors that the upgrades were necessary because the prior stabilizers had been damaged beyond repair; (b) the stabilizers had to be installed to ensure that Unity could fly *at all*.

**I. Defendants’ February 25, 2021 Earnings Call (Q4 2020)**

306. During the Company’s Q4 2020 earnings call held on February 25, 2021, Defendant Colglazier stated:

We’ve decided to implement enhancements and accelerate for the long-term maintenance updates to our mothership, Eve, that will improve the predictability and frequency of flight rate. To avoid sequential downtimes, we will also implement some additional enhancements to Unity during this period that will also improve predictability of flight rate. We expect the combined analysis and refurbishment period for all three vehicles to run for approximately four months.

307. Colglazier’s statements that the Company had decided to “implement enhancements” to Eve and Unity were materially misleading because the vehicles, in fact, needed major repairs or improvements, not mere “enhancements.” For example, materials for a March 24, 2021, Board meeting reveal that Unity required “structural modifications” that would take at least six months to make while Eve needed “engine upgrades, pylon replacement and structure modifications.” The significant ongoing problems with the vehicles, including insiders’ reports of the cracks that formed in both vehicles following flights, the fact that the pylon still had not been replaced after it was recommended to the Board in November/December 2019, and the timing of the March 2021 Board meeting fewer than four weeks after the Q4 2020 earnings call, shows that Colglazier was aware of the need for significant “structural modifications” rather than mere “enhancements” on both vehicles when the foregoing statements were made, or he was reckless in

not knowing when he made these statements about the decision to “implement enhancements” to both vehicles.

**J. Virgin Galactic’s 2020 Form 10-K, filed March 1, 2021**

308. The Company’s 2020 Form 10-K stated the following about the remaining path to commercial development:

We are *now in the final phases of readying our commercial spaceflight program*. As part of this preparatory work, we have transitioned our operational headquarters to our purpose-built facility at Spaceport America in New Mexico and *completing the final work on VSS Unity for commercial service, including the installation of the cabin interior*. The interior furnishings and fixtures have been installed at Spaceport America, along with finalizing everything needed to prepare our first future astronauts for flight.

309. The statement that the Company was in the “final phases” of readying for commercial flight and, thus, focused on “the installation of the cabin interior” was materially misleading because both vehicles, in fact, needed major repairs or improvements to be prepared for regular commercial operations. For example, materials for a March 24, 2021, Board meeting reveal that Unity required “structural modifications” that would take at least six months to make while Eve needed “engine upgrades, pylon replacement and structure modifications.” The problem with Eve’s launch pylon was ongoing, previously reported to the Board in or around December 2019.

**K. Defendants’ May 10, 2021 Earnings Call (Q1 2021)**

310. On the Q1 2021 earnings call held May 10, 2021, an analyst asked Defendants about “the move toward commercial service” and, in particular, the “point between the third flight [*i.e.*, Branson’s flight] and then that path to commercial [service].” In response, Defendant Colglazier reiterated that Branson’s flight would occur in the summer, the timeline to and further stated the following about Eve and Unity:

So Eve, which we've talked about a little bit today, have some upgrades and modifications that have been planned as well as Unity, and *both Eve and Unity's upgrades and modifications are to help give them, I'll call it, more reliability of predicting flight cadence as we shift those ships into commercial service.* We also will be then doing updates on the first of our SpaceShipThree vehicles, VSS Imagine, and making the modifications there as we go from live flight testing and then begin preparing for powered flight testing following these modification periods. So following that kind of period of modification and upgrade, Adam, is when we would move into commercial service. And *we'll start commercial service with Spaceship Unity and Eve.*

311. The foregoing statements were materially false and misleading because: (a) Eve and Unity did not require mere “upgrades and modifications” to help give them “more reliability of predicting flight cadence”, rather, they required serious repairs or changes, including for Eve “engine upgrades, pylon replacement and structure modifications”; (b) the suggestion that Eve and Unity would be used for commercial service after Branson’s summer 2021 flight was misleading where Defendants failed to disclose that the vehicles were mere prototypes not designed for commercial service and that could not withstand ongoing, recurring commercial use at a reasonable pace.

312. Also during the Q1 2021 earnings call, in response to direct analyze inquiry about Eve’s lifespan and commercial use in light of the vehicle’s age, Defendant Colglazier assured investors that Eve was still near the beginning of its commercial use life:

**Q:** I guess two things. I’m just trying to picture—there have been a few questions sort of gone around this. But first is, Eve is, I believe, about 13 years old at this stage. You’ve now got the Spaceship 3 coming out, which is great. So you’ve got these assets how—I mean *how long-lived do you expect them to be. I’m thinking both just in terms of what anomalies you might be looking for on the test flights, as well as, just the aging of these aircraft* in very different environment than we’ve seen for—in most—for most other types of aircraft.

**DEFENDANT COLGLAZIER:** Sure. I’ll start out, and gentlemen, feel free to kick in. *So, Eve—and I don’t recall the exact age, but let’s go with 13 years, as you said—is not flown a lot right? It’s not like a commercial airliner flying back and forth every day, putting flight hours on it at that time. So its number of flight hours, I’d say, are reasonably modest as far as airframes go.*

*Eve is important to make sure that as we move into commercial service that it has gone through some updates, modifications that will allow it to fly with consistent cadence, right? That's really what we're looking to do there, so that we're not kind of looking on a flight by flight basis and making sure we're ready, that we've got good predictability if we need people to be able to plan their trips to us and things like that.*

*So I think that's kind of normal evolution for Eve from a flight test program there. I'll let Mike or Swamy comment on age. But I would kind of highlight from a hours basis, it's still fairly low use I guess compared to a normal airframe.*

313. Defendant Colglazier's statements were materially misleading because: (a) because Eve was a flimsy prototype not suitable to ongoing, repeated commercial use, it was misleading to attempt to assure investors that the vehicle was near the beginning of its commercial life; (b) suggesting Eve had advantages over aluminum framed aircraft "when it comes to lifetime" because Eve was a composite vehicle was misleading where Defendants failed to disclose that Eve constantly developed cracks that needed to be repaired after flights; (c) Eve suffered so much more damage on its flights than an airliner so its remaining useful life was short.

**L. Branson's July 11, 2021 Interview**

314. On a July 11, 2021 Bloomberg Markets interview, Defendant Branson stated:

**Q:** Well, what does it mean for the company? There was some risk involved. I'm sure that some of your staff looking at me right now were nervous at points.

**Defendant Branson:** *Well, look, the company is 17 years old, they've had a number of flawless flights. They've never had any major, major technical issues even, you know, in the last 17 years and this [flight] was absolutely and utterly flawless.*

315. These statements were false and misleading: (a) straying from the landing cone and FAA airspace was a "major technical issue"; (b) Branson's flight was a major milestone, based on which Virgin Galactic planned to raise hundreds of millions of dollars in share and ticket sales; (c) the characterization of the flight as "absolutely and utterly flawless" is not consistent with the

major safety problems encountered on the flight and the regulatory response that was sure to follow.

**M. Defendants’ August 5, 2021 Earnings Call (Q2 2021)**

316. On the Q2 2021 earnings call held August 5, 2021, Defendant Colglazier stated the following about the July 2021 flight:

Our Unity 22 flight in July was a landmark achievement after 17 years of research, engineering, and innovation. *We executed a successful spaceflight* with a full crew in the cabin. *Unity 22 demonstrated further proof of our technical readiness* and we were able to share this event with the world as over 19 million viewers around the globe enjoy the excitement and wonder the spaceflight experience through our livestream and live television broadcast. Watching VSS Unity streak once again above the atmosphere arc back towards Earth into a perfect viewing position and feather gracefully for return to Spaceport America *validated the inherent safety and design of our system.*

\* \* \* \* \*

*While all safety and flight-related elements from the ships performed as expected*, the live video feed from the cabin to the ground experienced intermittent connection and we are reworking the video transmission system for our next flight. *This is not a flight issue and it’s not a safety issue*, but it is relevant to our consumer experience and we want to have it resolved for our next flight, Unity 23.

317. Colglazier’s statements that the July 2021 flight was “successful”, “demonstrated further proof of our technical readiness”, and “validated the inherent safety and design of our system” and that “all safety and flight-related elements from the ships performed as expected” were materially false and misleading for the same reasons Branson’s rosy statements about the supposed success of the flight were materially misleading. In addition, by the time of Colglazier’s statement on August 5, 2021: (a) the FAA had already discovered that Virgin Galactic’s representations that there were no issues on the flight, made to the FAA in a post-flight debrief, were false because Virgin Galactic strayed from its FAA airspace; (b) Virgin Galactic had already then admitted that straying from FAA airspace was a major deviation that should not happen again; (c) Virgin Galactic had delivered a high-level presentation to the FAA taking responsibility for the

deviation and promised the FAA that it would not happen again; and (d) Colglazier had been informed of all of these steps.

318. Also on the Q2 2021 earnings call, Defendant Colglazier stated the following to reassure investors about the Eve enhancement period:

**Q:** Thank you. And our last question is about, the enhancement period sounds very important for scaling and efficiency. There are a lot of variables that may be out of your control. What are risk factors and what will be the tougher aspects of the enhancement period, as we're all living in a very dynamic environment right now? Thank you.

**DEFENDANT COLGLAZIER:** Sure. *Functionally, this is kind of a life extension program on Eve, and so that's I think very well known in the aerospace industry of how to go about that.* So I'll leave it at that. As you mentioned, we're keeping an eye on the pandemic, we're keeping an eye on what that will do to allow us to bring our teams in and work efficiently together. That I'd say is one that, like everyone is hoping, it's not a risk to the system, but it's one that we're clearly keeping our eyes on. That's probably our biggest thing that I'm focusing on for the risk profile. We're still finishing the designs. This is an idea that was brought forth and proposed at the end of July. So we definitely want to close the design process and be fully confident in the scope. But we wanted to share our best look at that today was adding an additional four months going forward.

319. Defendant Colglazier's statement was false because: (a) the enhancements at issue were not predictable "life extension program[s]" but a complete replacement of important parts of Eve; (b) Colglazier's assertion that the repairs were a "life extension program" presumed that Eve had a known service life incorporated into its initial design and that the life can be extended based on data and analysis; (c) in reality, the enhancements at issue were a prototype-to-operation program whose parameters are unpredictable, in part because aerospace companies rarely attempt to convert prototypes to operational vehicles; and (d) because Defendants did not have accurate "as built" engineering drawings of Eve, the timeline for modifications was inherently unpredictable compared to a vehicle whose design was understood.

**N. Defendants' May 5, 2022 Earnings Call (Q1 2022)**

320. On a May 5, 2022, call to discuss Q1 2022 earnings, in response to a question about the “enhancement actions on Unity and Eve”, Defendant Colglazier stated that:

**Q:** That’s really helpful. And then also, when we think about the enhancement actions on Unity and Eve, can you describe the milestones you’ve already achieved? You’ve been going through the process for 8 months now. So I’d imagine you guys have accomplished quite a lot. Can you just share with us what some of those milestones have been?

**DEFENDANT COLGLAZIER:** Sure. And the teams have just been amazing to watch them go on this because, again, our existing team got a 2 to 3x ramp-up in work. And obviously, we’re growing again then for the future. So people have really stepped up. Unity is in solid shape. It will be the scope that we gave Unity, it will complete, I’ll call it, on our original schedule. So the Unity team will probably have some time just to do a few extra bonus items there.

Eve is really the ship that’s got the longer piece of time in there. But the milestone that we put in the presentation today was talking about the launch pylon. For those who aren’t familiar with kind of what’s going on our ships, it’s probably a hard picture to understand. But this is the piece that attaches the spaceship to the center of the wing and the mothership, not only at a structural level, but also this is where all the electricity moves through there, the air moves through there. I’s a very important part.

And the original design of that had 3 points, and that was fine for the work and the efforts we were doing with it in-flight test. But as we move into commercial service, we just want to open up the envelope of conditions that we would fly within and we wanted something structurally much, much more robust. But it’s going in and doing some reasonable amount of surgery on to the wing and opening that up.

*And so you saw that picture coming in back in April, where we are actually able to fit a new part into an existing effort in the wing with all the structural efforts kind of done and ready to go. That was a big milestone. We actually brought everybody together, got a big picture around that.*

*So I think that was the biggest one we’ve seen, and that was also kind of just a good one to have behind us, right?* So now we have more things to fit and finish up. But as far as big, big milestones, that was the one that we went through in April, and we were pleased to see it.

321. Defendants’ highlighted statements, including the statement that Eve had “all the structural efforts kind of done and ready to go,” were misleading because the new pylon required that Virgin Galactic make additional structural changes, including strengthening Eve’s wings.

## **VIII. ADDITIONAL FACTS FURTHER PROBATIVE OF SCIENTER**

**A. Branson Offloads Virgin Galactic**

322. Defendant Branson founded Virgin Galactic as a vanity project in 2004. By the beginning of the Class Period, Virgin Galactic had spent about a billion dollars, almost all of them Branson's. Taking Virgin Galactic public offered Branson a chance to offload responsibility for its continued funding while creating a liquid market in which he could sell his shares. But, as set out above, to push through the Reverse Merger, Defendants had to convince investors that Virgin Galactic was on the verge of commercial spaceflight, not in the middle of testing vehicles that would only ever be capable of a handful of flights per year, after each of which Virgin Galactic would have to undertake costly repairs.

323. Branson was able to make more than \$150 million selling his Virgin Galactic stock in the Reverse Merger.

324. Virgin Galactic began exploring a merger with Social Capital at an October 17, 2018 meeting between a Virgin director and an employee of Social Capital's investment advisor. After the meeting, Defendant Palihapitiya authorized the banker to proceed with discussions. After a flurry of meetings, on January 24, 2019, Social Capital sent Virgin Galactic an initial non-binding letter of intent. In the letter, Social Capital proposed to acquire portions of Virgin Galactic and its Branson-owned sister company, Virgin Orbit, which sends satellites to space. Social Capital suggested an initial valuation of the \$1.5 billion for the two companies combined.

325. After repeated discussions with Virgin Galactic, on February 5, 2019, Social Capital provided an amended valuation of \$2.0 billion, but also included a crucial new term: Virgin Galactic would purchase up to \$100 million of shares held by a company 80.7% owned by Branson, Vieco 10 Ltd., and its subsidiary Vieco USA, Inc. (collectively, "V10") in the Reverse Merger ("Branson Side Purchase"). Branson would thereby withdraw \$80.7 million in cash from

Virgin Galactic. In successive versions of the transaction documentation, the amount of the Branson Side Purchase would only increase.

326. After further discussions with Virgin Galactic, Social Capital agreed to limit discussions to Virgin Galactic, leaving Virgin Orbit as a side business. On March 2, 2019, Social Capital provided another letter of intent. In this letter, Social Capital valued Virgin Galactic at \$850 million. Yet, at the same time, Social Capital agreed to increase the amount of the Branson Side Purchase to up to \$150 million, or more than one sixth of the business's total value. In a revised April 3, 2019 letter of intent, Social Capital increased Virgin Galactic's valuation to \$1.3 billion, and also increased the Branson Side Purchase to up to \$200 million.

327. But Branson wanted to sell even more shares. So he proposed an additional term which required Palihapitiya to purchase an additional \$100 million of V10's shares on top of the Branson Side Purchase. The amendment did not change the valuation of Virgin Galactic, it only meant that Branson made more money from selling shares.

328. The parties continued to negotiate other terms and, on July 9, 2019, executed an agreement which valued Virgin Galactic at \$1.3 billion and provided that V10 would sell up to \$200 million of its Virgin Galactic shares to Virgin Galactic and would sell \$100 million of its Virgin Galactic shares to Palihapitiya.

329. Branson could not exercise the Branson Side Purchase in full. The SPAC's terms allowed shareholders to tender their Social Capital shares for about \$10 each. To ensure Virgin Galactic had enough cash after the Reverse Merger, the Branson Side Purchase required Virgin Galactic to still have \$500 million after its exercise. If too many shareholders tendered their shares, then Branson could not exercise the Brandon Side Purchase in full.

330. In the end, shareholders holding \$159.8 million of Social Capital stock tendered their shares, leaving only about \$52.1 million to purchase V10 shares, plus \$100 million from Palihapitiya, and Social Capital's trust fund with exactly \$500 million, before expenses.

331. Branson had an immediate need for the cash.

332. Branson founded Virgin Atlantic in 1984. It is the crown jewel of his empire. In a December 1, 2019 letter, Branson claimed "I have always viewed Virgin Atlantic as one of my children."<sup>16</sup>

333. Virgin Atlantic was his first airline. Branson would later found several more airlines, and in each case disposed of most of his shares. But while Branson later sold *part* of Virgin Atlantic to Delta, he kept 51% of Virgin Atlantic's shares for himself, thus maintaining control.

334. In May 2017, Branson agreed in principle to sell 31% of Virgin Atlantic to Air France-KLM for about \$282 million. Branson would thus lose control over Virgin Atlantic. In the December 2019 letter, Branson stated that he only reached the agreement "reluctantly." The agreement would not close for several years.

335. Branson agreed to the terms because he was cash poor. As Branson himself would later claim in seeking a government bailout from the UK, that "[o]ver the years significant profits have never been taken out of the Virgin Group, instead they have been reinvested in building businesses that create value and opportunities." Responding to the obvious objection – why should a government bail out a billionaire?—he explained "I've seen lots of comments about my net worth—but that is calculated on the value of Virgin businesses around the world before this crisis, not sitting as cash in a bank account ready to withdraw."

---

<sup>16</sup> <https://www.virgin.com/branson-family/richard-branson-blog/letter-virgin-atlantic-employees>

336. As of May 2017, most of Branson's companies were private, meaning that he could not easily sell their shares to meet his pressing needs for cash.

337. The cash he raised in Virgin Galactic's Reverse Merger was enough for Branson to keep his controlling interest in Virgin Atlantic, particularly as Branson could now sell Virgin Galactic stock on the open market when he needed more cash. A month after the Reverse Merger closed, Branson published the December letter to explain that he would no longer sell any Virgin Atlantic shares to Air France-KLM. By pushing through the Virgin Galactic Reverse Merger, Branson kept his majority control over Virgin Atlantic.

338. After the Reverse Merger, Branson sold every share he was allowed to sell before October 2021.

- a. On May 14-22, 2020 V10 sold 23.7 million shares for total proceeds of \$358.8 million;
- b. On June 2, 2020, V10 sold 12.5 million Virgin Galactic shares for total proceeds of \$188.3 million;
- c. V10 then dissolved and distributed all its Virgin Galactic shares to its shareholders in proportion to their shareholdings of V10;
- d. From April 12 through 14, 2021, Branson sold 5.584 million shares for total proceeds of \$150.3 million;
- e. On August 10-12, Branson sold 10.4 million shares for total proceeds of \$299.9 million.

339. In addition, on November 11, 2021, Branson sold 15.6 million shares for total proceeds of \$300 million.

340. V10 had agreed to a two-year lockup that prevented it from selling more than 50% of the Virgin Galactic shares it received in connection with the Reverse Merger (after giving effect to the sale of \$152.1 million of shares in the Reverse Merger). When V10 dissolved, it distributed proportionate shares of locked up and sellable shares to its shareholders.

341. With his 80.7% share of V10, Branson had to keep at least 46.3 million shares. With the August sales, Branson’s stake fell to just those 46.3 million locked up shares. Thus, Branson sold every single share he could in the Reverse Merger, and then sold every single share he could before October 2021:

Entity	Proceeds from IPO Sale	Gross Proceeds between 7/10/2019 - 8/4/2022	Percentage Branson ownership	Proceeds represented by ownership %
V10	\$152,095,620	\$667,829,074	80.70%	\$580,979,228
Branson – before end of lockup	0	\$450,493,532	100.00%	\$450,493,532
Branson after end of lockup		\$300,000,000		\$300,000,000
TOTAL				\$1,331,472,760

342. The Virgin Galactic stock Branson sold also accounted for a substantial portion of his net worth. In July 2021, Forbes estimated Branson’s fortune at \$5.7 billion. Branson’s share of the V10 sales was \$581.0 million, and his personal sales (including the November 2021 sales) totaled \$750.5 million for total proceeds of \$1,331.5 million. His Virgin Galactic sales represented more than 20% of his wealth.

343. Branson’s stock sales were a logistical challenge. Virgin Galactic is a relatively small company, and after the Reverse Merger, Branson’s V10 held approximately 58.6% of its shares. As a result, to generate meaningful proceeds, Branson would have to sell significant portions of Virgin Galactic’s total outstanding shares. For example, V10’s May 14-22, 2020, sales amounted to more than 10% of Virgin Galactic’s then-outstanding shares. Sales of such large

portions of Virgin Galactic's total shares predictably would cause Virgin Galactic's share price to collapse, both because of the number of shares released on the market and because the sales signaled Branson's lack of confidence in Virgin Galactic.

344. Branson's sales were timed strategically. Branson took advantage of the period between the Reverse Merger and the first of the delays that collectively showed that commercial spaceflight was still years away to sell more than 35 million of V10's shares. When Branson initiated his May 2020 sales, Virgin Galactic's stock was trading at its highest price since the Reverse Merger except for a three-week period from mid-February to March 2020. Companies customarily prevent executives and directors from selling shares immediately prior to an earnings announcement because they are presumptively in possession of material non-public information. Two of the weeks occurred immediately before Virgin Galactic announced its Q4 2019 earnings, where Branson presumably would not have been allowed to sell shares. Thus, Branson likely could not have taken advantage of the high trading price. And while Branson realized a lower price than Virgin Galactic's May 9, 2020, market price, that is the foreseeable consequence of announcing the sale of a large block of Virgin Galactic's shares. Branson's May 10, 2020, announcement that he might sell more than a billion dollars of Virgin Galactic stock, and his May 11, 2020, announcement that he would sell up to \$500 million, caused Virgin Galactic's stock price to fall from \$20.18 to \$17.60, or 13%, in two days.

345. Branson resumed sales in the first days of June 2020, just as Virgin Galactic was recovering from the stock price decline caused by his May 2020 sales. Branson again realized a lower price because Virgin Galactic's stock price fell from \$17.52 to \$15.82 (6.0%) on June 2 when rumors broke that Credit Suisse was marketing a large block of V10's shares.

346. Virgin Galactic's stock price recovered again in mid-July 2020 on news of Colglazier's appointment as CEO, but Branson likely could not have taken advantage of the increase because of a blackout period preceding the announcement of Virgin Galactic's Q2 2020 earnings. Nor could Branson be certain that Colglazier would accept the position or the timing of its announcement.

347. Branson resumed trading on April 12, when he sold \$150 million of Virgin Galactic stock. Branson's sales came just three weeks after Virgin Galactic's March 24, 2021 Board Meeting, where he was told of Unity and Eve's extensive defects.

348. Branson sold twice that on August 10-12, 2021. At the time, Branson knew that his flight had not been, contrary to his statements, "perfect". While Branson realized lower prices than the previous week's trading price, his sales are to blame: his August 10-12 sales caused Virgin Galactic's stock price to fall from \$35.21 to \$25.94 (26.3%) in three days.

**B. Virgin Galactic Raised More than \$1.3 Billion from Investors During the Class Period**

349. Virgin Galactic ended 2018 with annual revenues of \$2.8 million, annual expenses of \$139 million, and \$74.0 million in cash. Virgin Galactic urgently needed another cash infusion and had no realistic option other than the SPAC.

350. Like Branson, Virgin Galactic sold eye-popping amounts of its stock during the Class Period after the Reverse Merger:

- a. On August 5, 2020, Virgin Galactic sold 23,600,000 shares of stock at \$19.50 each for total proceeds of \$460.2 million;
- b. Between July 12 and July 16, 2021, Virgin Galactic sold 13,740,433 shares in an at-the-market offering for total proceeds of \$500 million; and

- c. On January 19, 2022 Virgin Galactic sold \$425 million of senior notes which can be converted into stock.

**C. Palihapitiya Needed the Virgin Galactic Reverse Merger to Close To Prevent It and His Four Other SPACs From Failing**

351. Palihapitiya's ambitions, in his words, was "to be our generation's Berkshire Hathaway".

352. Unlike Warren Buffet, Palihapitiya wanted to grow his fortune by acquiring private companies, using SPACs. He was dubbed the "King of SPACs."

353. Social Capital, with ticker symbol IPOA, was Palihapitiya's first SPAC. As the clock ticked to September 18, 2019, Social Capital's dissolution date, Palihapitiya had just one potential partner with whom discussions were far along enough to succeed: Virgin Galactic. Having invested his money, time, and self-image in SPACs, Palihapitiya had to push the Virgin Galactic Reverse Merger through.

354. IPOA's terms provided that if a Reverse Merger closed, the SPAC's sponsors would receive 20% of the SPAC's shares in the new company at no cost to the sponsors. For example, if Virgin Galactic's former shareholders held 75% of the new public company, then the sponsors would be awarded 5%, and the remaining 20% would be held by the SPAC's former shareholders (including the SPAC's sponsors to the extent they purchased SPAC shares outright). If no Reverse Merger closed, then the sponsors would not be awarded any additional shares. The fund would return the money to its investors, and the SPAC's owners would only receive amounts proportional to the amount they had actually invested. Thus, to make any money, Defendant Palihapitiya had to close the Reverse Merger.

355. But far worse, Social Capital was Palihapitiya's very first SPAC. If it failed, he would have a hard time convincing investors to invest more money or private companies to partner with him, including the four additional SPACs Palihapitiya had already taken through their IPOs.

356. During the Class Period, Palihapitiya disposed of every Virgin Galactic share he personally held:

- a. On December 14 and 15, 2020, Palihapitiya sold 3.8 million personally-held shares for total proceeds of \$97.8 million; and
- b. On March 2 and 3, 2021, Palihapitiya sold his remaining 6.2 million personally-held shares for total proceeds of \$212.8 million.

357. Palihapitiya's December 14-15, 2020 sales were particularly suspicious. On December 12, 2020, Virgin Galactic attempted a test flight, in which Unity's rocket shut down prematurely. While it was disclosed that Unity's rocket shut down, the cause—EMI that would take months or more to fix—was not. Without disclosing this material adverse information about the December 12, 2020 flight, and further aware of material nonpublic information concerning the broader undisclosed protracted delay of the launch of the Company's commercial operations because Virgin Galactic's spaceships needed extensive repairs, on December 14 and 15, 2020, Palihapitiya sold 3.8 million personally-held shares for total proceeds of \$97.8 million.

358. Palihapitiya's March 2021 sales were also suspicious. These sales were made just about two weeks after the Company was forced to delay the powered test flight scheduled for mid-February 2021 and just a few weeks before the Virgin Galactic board discussed the need to make "structural modifications" to Unity that would take at least six months to complete, as well as "engine upgrades, pylon replacement and structural modifications" to Eve. The timing of these

events shows that Palihapitiya was aware of material undisclosed issues with Eve and Unity at the time he sold \$212.8 million worth of Virgin Galactic shares to unwitting investors.

359. In sum, Palihapitiya—who, behind only Branson, was Virgin Galactic’s second largest individual shareholder during the Class Period—sold his entire position in Virgin Galactic reaping more than \$310 million in gross proceeds in fewer than two years after the Reverse Merger closed taking Virgin Galactic public.

360. Palihapitiya has also made fantastical, demonstrably false statements about Virgin Galactic to woo investors. For example, on a July 9, 2019 CNBC interview, Palihapitiya stated that Virgin Galactic are **“licensed by the FAA. They have all the regulatory elements in place to start commercial operations.** That was a huge part of our justification.” Palihapitiya’s statement was not true. Virgin Galactic’s commercial license required it to verify 29 points. Even as of the end of 2019, five months after Palihapitiya’s statement, Virgin Galactic had completed just 10. The remainder would require additional test flights. During that same interview, Palihapitiya also stated that “how do we know that this thing is going to be an incredibly safe experience? It was at the end of that process that I bought my ticket because I just became convinced that ***this is actually as safe or safer, frankly, than flying in a traditional airplane.***”

361. Nor is Palihapitiya a stranger to business tort. He was ordered to pay almost \$16 million after a court found him liable for, among other things, conspiracy and knowing assistance in breach of fiduciary duty. *Extreme Venture Partner Funds I LP v. Varma*, 2019 ONSC 2907, available at 2019 WLNR 17995108 (Superior Court of Ontario, Canada). The elements of the latter are (1) a fiduciary duty (2) which the fiduciary breached fraudulently and dishonestly, (3) the defendant had actual knowledge of both the fiduciary relationship and the fiduciary’s fraudulent and dishonest conduct, and (4) the defendant participated in or assisted the fiduciary’s fraudulent

conduct. The court also found Palihapitiya's testimony "not credible", "contrived, and an attempt to get around the contemporaneous emails and documents that contradict their version of events." On many occasions, the court found that contemporaneous documents showed Palihapitiya's had made false statements on the stand and strongly suggested that Palihapitiya had attempted to mislead through his testimony.

**D. Virgin Galactic Is A Small Company and Whitesides Worked There For More than a Decade**

362. Defendants Whitesides joined Virgin Galactic in 2010, when it had only 30 employees.

363. Until at least 2019, Whitesides worked out of Virgin Galactic's headquarters in the Mojave Air & Space Port in Mojave, California.

364. Virgin Galactic's Mojave Desert offices were very small. While Virgin Galactic boasts that its campus has over 200,000 square feet, the majority consists of outdoor parking/storage space.

365. According to FE 7, Virgin Galactic principally worked out of two buildings. Exhibits to Virgin Galactic's October 10, 2019 proxy show these buildings are Building 79B, with 26,955 square feet of building space, and Building 79 West, with approximately 48,000 square feet of building space.<sup>17</sup>

366. The majority of Building 79 West was given over to the hangar that housed Unity, Eve, and other vehicles in process and finished parts, leaving very little office space.

367. As a result, employees were packed together in a small space. FE 7 commented that

---

<sup>17</sup> Building 79 West is known internally as the Final Assembly, Integration, and Test Hangar, or FAITH.

Virgin Galactic’s offices (and team) were “very, very small.”

368. FE 2 worked in the hangar building. He reports that the hangar building had an open office design continuous with the hangar itself. Whitesides and some other engineers and executives, worked on an elevated platform that overlooked the hangar. The only thing that obstructed Whitesides’s view of Unity and Eve and the technicians working on them was a guardrail to prevent people from falling to the hangar floor. Whitesides was located right next to the engineers, too. FE 2 could “walk ten feet” and talk to them.

369. FE 9 sat close to Whitesides and saw him on a daily basis. According to FE 9, Whitesides would necessarily have known of the delays and problems because Whitesides was “right there” in the office every day.

370. In sum, Virgin Galactic’s core operation—preparing Unity and Eve for commercial spaceflight—was also the view from Whitesides’s open office:





371. Indeed, according to FE 9, the extensive patching and repairs were so unmistakable that Virgin Galactic employees frequently had to put on ear coverings to block noise from activities in the hangar.

372. Further, Defendant Whitesides would have known of deficiencies in Unity and Eve because Virgin Galactic's engineers were terrified of flying in them. According to FE 9, Virgin Galactic organized a raffle amongst its employees for a chance to fly on Unity. Employees had to opt into the raffle. FE 9 spoke to at least 10 of FE 9's colleagues in Engineering about the raffle. None of them put their names in the hat because they believed Unity and/or Eve were unsafe.

#### **IX. ADDITIONAL FACTS PLEADING COLGLAZIER'S SCIENTER**

373. On January 23 and 24, 2025, Plaintiffs took the deposition of Michael Moses.

374. Moses testified that he had personally communicated to Colglazier, before Colglazier's August 5, 2021 statements, that, on Unity 22 (*i.e.*, the July 2021 test flight): (1) emergency messages had been displayed showing that Unity had left its glide cone; (2) Unity had

in fact left its glide cone; (3) Unity had left its FAA airspace; (4) the FAA was investigating Unity's leaving its FAA airspace and failing to communicate thereon; and (5) Virgin Galactic had delivered a presentation to the FAA on August 3, 2021, concerning Unity's departing from its FAA Airspace and the contents thereof.

375. In aviation, Crew Alerting System (usually shortened to "CAS") messages provide information to the crew about conditions that need attention. The two highest-priority messages are CAUTION (amber), used to communicate a condition that requires immediate crew awareness, and WARNING (red), which communicates an emergency or condition that requires immediate corrective or compensatory crew action. In Unity, the CAS messages are accompanied by a light. CAUTION messages are accompanied by an amber light; WARNING messages by a red light.

376. Moses confirmed in his testimony that, as set out above, on Unity 22, both amber CAUTION and red WARNING CAS messages were displayed during Unity's boost phase. These CAS messages stated that Unity was leaving, and then had left, its entry glide cone.

377. On June 28, 2021, Virgin Galactic senior manager Bill Kuhlmeier circulated a series of PowerPoint slides setting out key points for the upcoming Unity 22 flight. VGH-LAVIN00043855. These slides included, among other things, "ROE," or "Rules of Engagement." One of the slides stated that "RED CAS Message During Boost = **ABORT.**"

378. Moses testified that on Unity, CAS messages and the accompanying light are displayed on the cockpit itself rather than on a helmet-mounted display. The CAS messages themselves appear on three different displays (one on the pilot's side, one on the co-pilot's side, and one in the middle). The light appears on a dashboard at eyebrow level. Moses testified that Unity cabin occupants have an unobstructed view of CAS messages and the light.

379. Further, Moses testified that it is Virgin Galactic's standard operating procedure for co-pilots to read out CAS messages when they are displayed. On Unity 22, cabin occupants and pilots used the same audio feed. Thus, cabin occupants heard the co-pilot read out the CAS messages.

380. Moses testified that he learned that the pilots had received red WARNING CAS messages on Unity 22 on the day of the flight.

381. On the day of the flight, Virgin Galactic held a post-flight debriefing. Moses testified that the post-flight debriefing was attended by more than 60 people, including everyone who had a console in mission control, the maintenance leads, the propulsion team, the four Unity and Eve pilots, senior flight leadership, representatives of the safety team, medical personnel, training personnel, and the FAA. It was discussed at Unity 22's post-flight debrief that red WARNING CAS messages concerning Unity's entry glide cone were displayed during the boost phase of Unity 22.

382. Moses testified that he told Colglazier that Unity 22 had experienced red WARNING CAS messages concerning the entry glide cone either on the day of the flight (July 11) or the day after the flight (July 12).

383. Virgin Galactic designates a SPACESUP (short for Spaceship Supervisor, Pilot) for each flight. The SPACESUP is a pilot who sits in the control room. The SPACESUP is responsible for communicating with the pilots and making certain important decisions. The SPACESUP has the authority to abort the mission. The SPACESUP on Unity 22 was Nicola Pecile.

384. Moses testified that at the post-flight debriefing, and again at a pilot debriefing which occurred a day or two later, Pecile stated that he should have aborted the flight when the red WARNING CAS message appeared during the boost phase.

385. On July 23, 2021, the FAA informed Virgin Galactic that it was investigating Unity's leaving its FAA Airspace during Unity 22 and failing to disclose same to the FAA. Moses testified that he learned about the FAA's investigation the same day as Virgin Galactic (i.e., on July 23). Moses testified that he also told Colglazier about the investigation that same day (July 23), as well as the subject thereof.

386. Moses testified that thereafter, he provided regular updates to Colglazier thereafter concerning the FAA investigation and Unity leaving its FAA Airspace.

387. On August 3, 2021, the Unity 22 pilot, David Mackay, delivered a presentation to the FAA concerning Unity leaving its airspace. In the presentation, Mackay acknowledged that Virgin Galactic had erred by failing to inform the FAA that Unity had left FAA airspace. Additional facts about the presentation are set out at ¶249, above.

388. Moses testified that he and other Virgin Galactic employees held a prep session on August 2, 2021 in which they ran through the presentation.

389. Moses testified that he informed Colglazier of the August 3 meeting and its subject before the meeting occurred.

## **X. CLASS ACTION ALLEGATIONS**

390. Plaintiffs bring this action as a class action pursuant to Rules 23(a) and 23(b)(3) of the Federal Rules of Civil Procedure on behalf of a class consisting of all those who purchased or otherwise acquired the Company's common stock during the Class Period, and who were damaged thereby (the "Class"). Excluded from the Class are (i) Defendants, (ii) officers and directors of

Virgin Galactic and Social Capital at all relevant times, and all subsidiaries thereof; (iii) persons or entities who held shares of V10 as of July 9, 2019, and all subsidiaries thereof; (iv) the family members, heirs, assigns, and legal representatives of all persons set out in (i)-(iv); and (v) all entities controlled by the persons set out in (i)-(iv).

391. The members of the Class are so numerous that joinder of all members is impracticable. Throughout the Class Period, the Company's common stock was actively traded on NYSE. While the exact number of Class members is unknown to Plaintiffs at this time and can only be ascertained through appropriate discovery, Plaintiffs believe that there are hundreds or thousands of members in the proposed Class. Record owners and other members of the Class may be identified from records maintained by the Company or its transfer agent and may be notified of the pendency of this action by mail, using the form of notice similar to that customarily used in securities class actions.

392. Plaintiffs' claims are typical of the claims of the members of the Class, since all members of the Class are similarly affected by Defendants' wrongful conduct in violation of federal law alleged herein.

393. Plaintiffs will fairly and adequately protect the interests of the members of the Class and have retained counsel competent and experienced in class action and securities litigation.

394. Common questions of law and fact exist as to all members of the Class and predominate over any questions solely affecting individual members of the Class. Among the questions of law and fact common to the Class are:

- (a) whether Defendants' acts constituted violations of the federal securities laws;

(b) whether Defendants' statements made to the investing public during the Class Period misrepresented material facts concerning the Company's business, operations, and financial condition;

(c) whether the price of the Company's common stock was artificially inflated during the Class Period; and

(d) to what extent the members of the Class have sustained damages and the proper measure of damages.

395. A class action is superior to all other available methods for the fair and efficient adjudication of this controversy since joinder of all members is impracticable. Furthermore, as the damages suffered by individual Class members may be relatively small, the expense and burden of individual litigation make it impossible for members of the Class to individually redress the wrongs done to them. Additionally, there will be no difficulty in the management of this action as a class action.

#### **XI. APPLICABILITY OF PRESUMPTION OF RELIANCE: FRAUD ON THE MARKET DOCTRINE**

396. At all relevant times, the market for the Company's common stock was an efficient market for the following reasons, among others:

(a) The Company's common stock met the requirements for listing, and was listed and actively traded on NYSE, a highly efficient, electronic stock market;

(b) As a regulated issuer, the Company filed periodic public reports with the SEC;

(c) The Company regularly communicated with public investors via established market communication mechanisms, including regular disseminations of press releases on the national

circuits of major newswire services and other wide-ranging public disclosures, such as communications with the financial press and other similar reporting services; and

(d) The Company was followed by securities analysts employed by major brokerage firms who wrote reports that were distributed to the sales force and certain customers of their respective brokerage firms. Each of these reports was publicly available and entered the public marketplace.

397. As a result of the foregoing, the market for the Company's common stock promptly digested current information concerning the Company from all publicly available sources and reflected such information in the prices of the Company's stock. Under these circumstances, all purchasers of the Company's common stock during the Class Period suffered similar injury through their purchase of the Company's common stock at artificially inflated prices and a presumption of reliance applies.

## **XII. NO SAFE HARBOR**

398. The statutory safe harbor provided for forward-looking statements under certain circumstances does not apply to any of the allegedly false statements alleged herein. Many of the specific statements alleged herein were not identified as "forward-looking statements" when made, and thus are not entitled to protection under the safe harbor provision. Additionally, to the extent that there were any forward-looking statements, there were no meaningful cautionary statements identifying important factors that could cause actual results to differ materially from those in the purportedly forward-looking statements. Alternatively, to the extent that the statutory safe harbor does apply to any forward-looking statements alleged herein, Defendants are liable for those false forward-looking statements because at the time each of those forward-looking statements were made, the particular speaker knew that the particular forward-looking statement was false, and/or

the forward-looking statement was authorized and/or approved by an executive officer of the Company who knew that those statements were false when made.

**COUNT I**  
**Violation of Section 10(b) of the Exchange Act and SEC Rule 10b-5 Promulgated Thereunder Against All Defendants**

399. Plaintiffs repeat and reallege each and every allegation contained above as though set forth in full herein.

400. During the Class Period, Defendants disseminated or approved the materially false and misleading statements specified above, which they knew, or were deliberately reckless in not knowing, were misleading. These statements were false and misleading because they contained misrepresentations and failed to disclose material facts necessary in order to make the statements made, in light of the circumstances under which they were made, not misleading.

401. Defendants: (1) employed devices, schemes, and artifices to defraud; (2) made untrue statements of material fact/and or omitted to state material facts necessary to make the statements made not misleading; and (3) engaged in acts, practices, and a course of business that operated as a fraud and deceit upon the purchasers of the Company's common stock during the Class Period.

402. Plaintiffs and the Class have suffered damages in that, in reliance on the integrity of the market, they paid artificially inflated prices for the Company's common stock. Plaintiffs and the Class would not have purchased or otherwise acquired the Company's common stock at the prices they paid—or at all—if they had been aware that the market prices had been artificially and falsely inflated by Defendants' misleading statements.

403. As a direct and proximate result of Defendants' wrongful conduct, Plaintiff and the other members of the Class suffered damages in connection with their purchases of the Company's common stock during the Class Period.

## COUNT II

### Violation of Section 10(b) of the Exchange Act For Insider Trading Against Defendants Virgin Galactic, Branson, and Palihapitiya

404. Branson and Palihapitiya were in possession of material non-public information at the time they sold their shares, including, among others, that: (a) the February 2019 flight had nearly ended in disaster; (b) Unity and Eve were not complete vehicles because many of their parts needed replacement, including Unity's horizontal stabilizers and its flight controls; (c) Unity and Eve were prototypes that cracked after every flight and took about a month to repair; and/or (d) Virgin Galactic did not have accurate engineering drawings of Unity and Eve.

405. Through its officers and employee, Virgin Galactic was in possession of non-public information at the time it sold its shares to the public, including, among others, that: (a) the February 2019 flight had nearly ended in disaster; (b) Unity and Eve were not complete vehicles because many of their parts needed replacement, including Unity's horizontal stabilizers and its flight controls; (c) Unity and Eve were prototypes that cracked after every flight and took about a month to repair; and/or (d) Virgin Galactic did not have accurate engineering drawings of Unity and Eve.

406. Virgin Galactic, Branson, and Palihapitiya knew such facts were material to investors.

407. As the sellers of \$2.7 billion of stock during the Class Period, Virgin Galactic, Branson, and Palihapitiya had a duty to either (a) refrain from selling stock, or (b) to disclose the material facts they were aware of, including, among others, that: (a) the February 2019 flight had nearly ended in disaster; (b) Unity and Eve were not complete vehicles because many of their parts needed replacement, including Unity's horizontal stabilizers and its flight controls; (c) Unity and Eve were prototypes that cracked after every flight and took about a month to repair; and/or (d) Virgin Galactic did not have accurate engineering drawings of Unity and Eve.

408. Plaintiffs and Class Members purchased or otherwise acquired Virgin Galactic shares contemporaneously with Virgin Galactic, Branson, and Palihapitiya's sales of shares.

409. Virgin Galactic, Branson, and Palihapitiya are liable to all persons purchasing Virgin Galactic shares contemporaneously with their sales of shares.

**COUNT III**  
**Violation of Section 20(a) of the Exchange Act Against Defendants Branson and Palihapitiya**

410. Plaintiffs repeat and reallege each and every allegation contained above as though set forth in full herein.

411. Defendants Branson and Palihapitiya acted as controlling persons of the Company within the meaning of Section 20(a) of the Exchange Act as alleged herein. By virtue of their high-level positions, and their ownership and contractual rights, participation in, and/or awareness of the Company's operations and/or intimate knowledge of the Company's statements filed with the SEC and disseminated to the investing public, Defendants Branson and Palihapitiya had the power to influence and control, and did influence and control, directly or indirectly, the decision-making of the Company, including the content and dissemination of the various statements alleged to be false and misleading herein.

412. Defendants Branson and Palihapitiya, moreover, were provided with, or had unlimited access to, copies of the Company's reports, press releases, public filings, and other statements alleged to be false and misleading herein. Defendants Branson and Palihapitiya were provided with, or had unlimited access to, such documents and statements prior to, and/or shortly after these statements were issued, and therefore had the ability to prevent the issuance of the statements and/or cause the statements to be corrected. Additionally, Defendants Branson and Palihapitiya had direct and supervisory involvement in the day-to-day operations of the Company

and had the power to control or influence the particular transactions giving rise to the securities violations.

413. Defendants Branson and Palihapitiya had ultimate authority over the Company's statements, including controlling the content of such statements and whether and how to communicate such statements to the public.

414. By reason of such conduct, Defendant Branson and Palihapitiya are liable pursuant to Section 20(a) of the Exchange Act.

**COUNT IV**  
**Violation of Section 20A of the Exchange Act Against Defendants Virgin Galactic, Branson and Palihapitiya**

415. Plaintiffs repeat and reallege each and every allegation contained above as if fully set forth herein. Count IV is brought pursuant to §20A of the Exchange Act against Defendants Virgin Galactic, Branson and Palihapitiya on behalf of Plaintiffs who were damaged by Defendants Branson and Palihapitiya's insider trading.

416. As detailed herein, Defendants Virgin Galactic, Branson and Palihapitiya were in possession of material, non-public information concerning Virgin Galactic. Defendants Virgin Galactic, Branson and Palihapitiya took advantage of their possession of material, non-public information regarding Virgin Galactic to obtain millions of dollars in insider trading profits during the Class Period.

417. Virgin Galactic, Branson and Palihapitiya's sales of Virgin Galactic common stock were made contemporaneously with Plaintiffs' purchases of Virgin Galactic common stock during the Class Period.

418. During the Class Period, Virgin Galactic sold shares contemporaneously with Plaintiffs as reflected by their certifications.

419. During the Class Period, Branson sold shares held through V10 and Virgin Investments Limited, entities that he controlled, contemporaneously with Plaintiffs, in the following amounts:

V10/Branson Sale			Contemporaneous purchaser			
Date	Quantity	Total proceeds	Purchaser	Date	Number of Shares Purchased or Acquired	Price
10/25/2019	15,209,562	\$152,095,620.00	Montgomery Brantley	10/25/2019	3	\$10.75
5/14-22/2020	23,700,000	\$358,809,101.76	Rosales	5/3/21	8	\$20.40
				5/11/21	6	\$18.15
				5/13/21	2	\$16.77
			Kusnier	5/20/2020	6000	\$15.2
				5/20/2020	370	\$15.3
				5/20/2020	400	\$15.3250
				5/20/2020	400	\$15.3300
				5/20/2020	5	\$15.2689
				5/20/2020	1	\$15.3250
			6/2/2020	12,500,000	\$188,327,742	Scheele
4/12-14/2021	5,584,000	\$150,325,613.10	Carlough	4/12/2021	1	\$27
			Kusnier	4/21/2021	482	\$22.0850
				4/21/2021	3000	\$22.1250
				4/21/2021	960	\$22.1282
				4/21/2021	135	\$22.0950
				4/21/2021	900	\$22.0100
				4/21/2021	200	\$22.0180
				4/21/2021	900	\$22.0200
				4/21/2021	2,216	\$22.0300
4/21/2021	8,754	\$22.0400				

			O'Keefe-Jones	4/16/2021	1.191508	\$23.08
8/10-12/2021	10,416,000	\$299,867,918.91	O'Keefe-Jones	8/13/2021	1.065099	\$25.82
			Ortiz	8/17/2021	0.45513	\$25.3450
				8/17/2021	19	\$25.3500
				8/17/2021	0.000394	\$25.3400
				8/17/2021	20	\$25.3400
				8/17/2021	4.909662	\$25.4600
				8/11/2021	0.098868	\$26.9550
				8/11/2021	36.99744	\$26.9570

420. Additionally, during the Class Period, Branson sold shares held through V10 and Virgin Investments Limited, entities that he controlled, contemporaneously with Plaintiff Cui as reflected by the previously filed certification (Dk. No. 40-1).

421. During the Class Period, Defendant Palihapitiya sold the following shares of Virgin Galactic contemporaneously with Plaintiffs:

Date	Quantity	Total Proceeds	Purchaser	Date	Number of Shares Purchased	Price
12/14-15/2020	3,800,000	\$97,826,680.32	Scheele	12/14/2020	1	\$26.6100
				12/14/2020	1	\$27.5
				12/14/2020	5,209	\$26.2100
			Gupta	12/17/20	1	\$24.89

3/2-  3/2021	6,200,000	\$212,771,951.36	Kusnier	3/4/2021	50	\$28.99
				3/4/2021	207	\$29.01
				3/4/2021	300	\$29.07
				3/4/2021	749	\$29.00
				3/4/2021	100	\$29.01
				3/4/2021	300	\$29.07
				3/4/2021	350	\$29.01
				3/4/2021	550	\$29.05
				3/4/2021	1670	\$29.06
				3/4/2021	400	\$29.03
				3/4/2021	9738	\$29.07
				3/4/2021	100	\$28.99
				3/4/2021	200	\$29.08
				3/4/2021	100	\$28.98
				3/4/2021	200	\$29.02
				3/4/2021	200	\$29.00
				3/4/2021	500	\$29.04
				3/4/2021	500	\$28.97
				3/4/2021	200	\$29.01
				3/4/2021	200	\$29.02
3/4/2021	250	\$29.03				
3/4/2021	18	\$28.98				
3/4/2021	200	\$29.03				

				3/4/2021	200	\$29.02
				3/4/2021	219	\$29.03
				3/4/2021	99	\$29.04
				3/4/2021	400	\$29.05
			Carlough	3/2/2021	1	\$35.20
				3/4/2021	17	\$29.21
			O'Keefe-Jones	3/5/2021	1.011773	\$27.18

422. Additionally, Defendant Palihapitiya sold the following shares of Virgin Galactic contemporaneously with Plaintiff Cui as reflected by the previously filed certification (Dk. No. 40-1).

423. Plaintiffs who purchased or otherwise acquired shares of Virgin Galactic common stock contemporaneously with sales by Branson and Palihapitiya suffered damages because: (1) in reliance on the integrity of the market, they paid artificially inflated prices as a result of the violations of §§10(b) and 20(a) of the Exchange Act as alleged herein; and (2) they would not have purchased or otherwise acquired the securities at the prices it paid, or at all, if it had been aware that the market prices had been artificially inflated by the false and misleading statements and concealment alleged herein.

#### **PRAYER FOR RELIEF**

WHEREFORE, Plaintiffs pray for relief and judgment, as follows:

A. Determining that this action is a proper class action, certifying Plaintiffs as Class representatives under Rule 23 of the Federal Rules of Civil Procedure and their counsel as Counsel for the Class;

B. Awarding compensatory damages in favor of Plaintiffs and the other Class members against all Defendants, jointly and severally, for all damages sustained as a result of Defendants' wrongdoing, in an amount to be proven at trial, including interest thereon;

C. Awarding Plaintiffs and the Class their reasonable costs and expenses incurred in this action, including counsel fees and expert fees; and

D. Such other and further relief as the Court may deem just and proper.

### **JURY DEMAND**

Plaintiffs hereby demand a trial by jury.

Dated: June 26, 2025

Respectfully submitted,

GLANCY PRONGAY & MURRAY LLP

By: s/ Natalie S. Pang  
Kara M. Wolke  
Ex Kano S. Sams II  
Natalie S. Pang  
Raymond D. Sulentic  
1925 Century Park East, Suite 2100  
Los Angeles, CA 90067  
phone: (310) 201-9150  
fax: (310) 432-1495  
Email: kwolke@glancylaw.com  
esams@glancylaw.com  
npang@glancylaw.com  
rsulentic@glancylaw.com

THE ROSEN LAW FIRM, P.A.

By: s/ Jonathan Horne  
Jonathan Horne, Esq. (JH 7258)  
Laurence M. Rosen, Esq.  
275 Madison Avenue, 40th Floor  
New York, New York 10016  
Telephone: (212) 686-1060  
Facsimile: (212) 202-3827  
Email: jhorne@rosenlegal.com  
lrosen@rosenlegal.com

*Counsel for Plaintiffs*